



FEATURES

- Asynchronous serial data transmission
- Automatic baud-rate fitting up to 115.2 Kbps
- Distance up to 1200 m
- Point to point connection or multipoint connection up to 32 modules
- DC or AC power supply
- Galvanic isolation on all ways
- RS232 connection on DB9 or removable terminals
- UL / CE mark
- Suitable for DIN rail mounting in compliance with EN-50022

GENERAL DESCRIPTION

The device DAT3580 is an isolated interface converter between asynchronous serials lines RS232 and RS485 or RS422 that guarantees a full isolation between power supply, serial line RS-232 and serial line RS-485 or 422 removes eventual ground-loop effects, allowing the use of the device even in the heavy environmental conditions.

It is designed to operate either on serial interface RS-422 full-duplex 4 wires or RS485 half-duplex 2 wires, with a baud-rate transmission up to 115.2 Kbps.

The transmission is asynchronous without settings of protocol, data format and baud rate.

On the line RS-232 are not necessary handshake commands (RTS, CTS, etc..) to control the baud rate.

DAT3000 series devices are designed to be easily mounted on DIN rail, optimizing the space encumbrance. Whereas the thermal dissipation allows it, the devices can be mounted side by side, allowing a relevant reduction of space requiring. The connections are made by means of removable screw terminals, to simplify the handling of the devices.

The DAT 3580 is in compliance with the Directive UL 61010-1 for US market and with the Directive CSA C22.2 No 61010-1 for the Canadian market.

The device is housed in a rough self-extinguishing plastic container DIN rail, thanks to its thin profile of 22.5 mm only, allows a high density mounting on EN-50022 standard DIN rail.

USER INSTRUCTIONS

Before to install the device, please read the "Installation Instruction" section.

The device DAT3580 converts the serial transmission from RS-232 to RS-485 (2 wires) or RS-422 (4 wires) as follows.

The data incoming from the line TX of RS-232 (DB9 connector pin 3) are converted and transmitted to the terminals D-E of RS-485 and RS-422.

The data incoming from the line RX of RS-485 (terminal D and E) or RS-422 (terminal B and C) are converted and transmitted to the terminal RX of RS-232 (DB9 connector pin 2).

The transmission of the signal follows the logic state of every single bit, then there is not necessary to set the protocol, the data format and the baud-rate.

When the transmission line from the RS-232 is off, the RS-485 driver is in the receive condition (high impedance); when the transmission line from the RS-232 goes on, the RS-485 driver switch immediately to the transmission condition (low impedance). The low impedance is kept for about 150 us, then the line returns automatically in high impedance (receiver).

TECHNICAL SPECIFICATIONS (Typical @ 25 °C and in the nominal conditions)

In compliance with standard		ISOLATION	
	EIA RS232, RS485 and RS422	Power supply / RS232	2000 Vac, 50 Hz, 1 min.
RS485 Interface		Power supply / RS485-422	2000 Vac, 50 Hz, 1 min.
Baud-rate	up to 115.2 Kbps	RS232 / RS485-422	2000 Vac, 50 Hz, 1 min.
Max. distance / baud-rate ratio (recommended) (1)	1.2 Km – 4000 ft @ 38400 bps 2 Km – 6560 ft @ 19200 bps 3 Km – 9840 ft @ 9600 bps 4 Km – 13100 ft @ 4800 bps 5 Km – 16400 ft @ 2400 bps 7 Km – 23000 ft @ 1200 bps	ENVIRONMENTAL CONDITIONS	
Number of modules in multipoint	up to 32	Operative Temperature	-20°C .. +60°C
Switching time TX/RX (RS485)	150 us.	UL Operative Temperature	-10°C .. +40°C
Internal terminator resistance (optional)	120 Ohm	Storage Temperature	-40°C.. +85°C
		Humidity (not condensed)	0 .. 90 %
		Maximum Altitude	2000 m
		Installation	Indoor
		Category of installation	II
		Pollution Degree	2
		MECHANICAL SPECIFICATIONS	
POWER SUPPLY		Material	Self-extinguish plastic
Power supply DC voltage	10 .. 30 Vdc	IP Code	IP20
Reverse polarity protection	60 Vdc max	Wiring	wires with diameter 0.8÷2.1 mm ² /AWG 14-18
Power supply AC voltage	9 ÷ 18 Vac (18 ÷ 30 Vac optional)	Tightening Torque	0.5 N m
Current consumption	35 mA max.	Mounting	in compliance with DIN rail standard EN-50022
		Weight	about 160 g.
Connection		CERTIFICATIONS	
RS-232	DB9 / removable screw terminals	EMC (for industrial environments)	
RS-485/422	removable screw terminals	Immunity	EN 61000-6-2
		Emission	EN 61000-6-4
		UL	
		US Standard	UL 61010-1
		Canadian Standard	CSA C22.2 No 61010-1
		CCN	NRAQ/NRAQ7
		Typology	Open Type device
		Classification	Industrial Control Equipment
		File Number	E352854
(1) – The maximum distance depends of: number of devices connected, type of cabling, noises, etc...			

INSTALLATION INSTRUCTIONS

The DAT 3580 is suitable for fitting to DIN rails in the vertical position. For optimum operation and long life follow these instructions:

When the devices are installed side by side it may be necessary to separate them by at least 5 mm in the following case:

- If panel temperature exceeds 45°C and high power supply value(> 27Vdc).

Make sure that sufficient air flow is provided for the device avoiding to place raceways or other objects which could obstruct the ventilation slits. Moreover it is suggested to avoid that devices are mounted above appliances generating heat; their ideal place should be in the lower part of the panel. Install the device in a place without vibrations.

Moreover it is suggested to avoid routing conductors near power signal cables (motors, induction ovens, inverters, etc...) and to use shielded cable for connecting signals.

CABLING

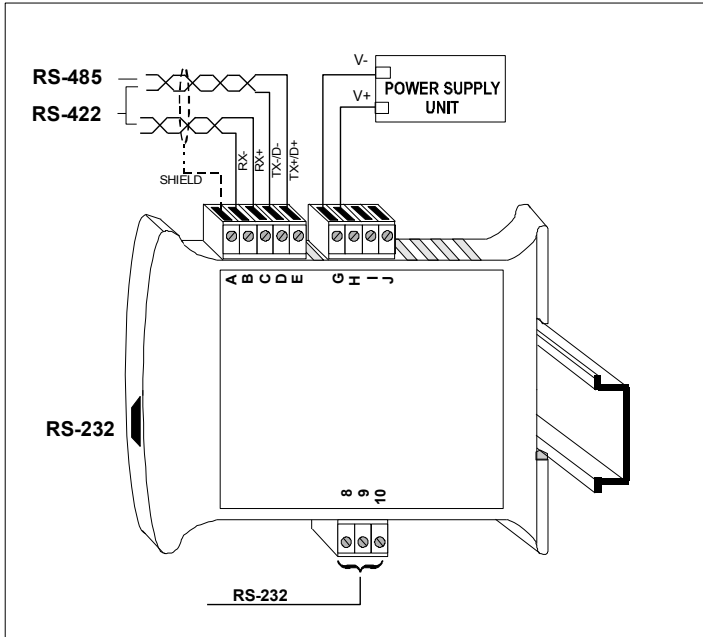

LIGHT SIGNALLING

LED	COLOUR	STATE	DESCRIPTION
PWR	GREEN	ON	Device powered
		OFF	Device not powered
TX	RED	FAST BLINK	Data transmitted from port RS232 (blink frequency depends to baud-rate)
		OFF	No communication in progress
RX	RED	FAST BLINK	Data received on port RS485/422 (blink frequency depends to baud-rate)
		OFF	No communication in progress

DIMENSIONS (mm)

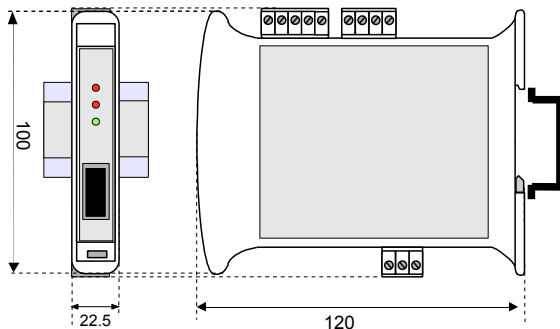

The symbol reported on the product indicates that the product itself must not be considered as a domestic waste. It must be brought to the authorized recycle plant for the recycling of electrical and electronic waste. For more information contact the proper office in the user's city, the service for the waste treatment or the supplier from which the product has been purchased.

WIRING

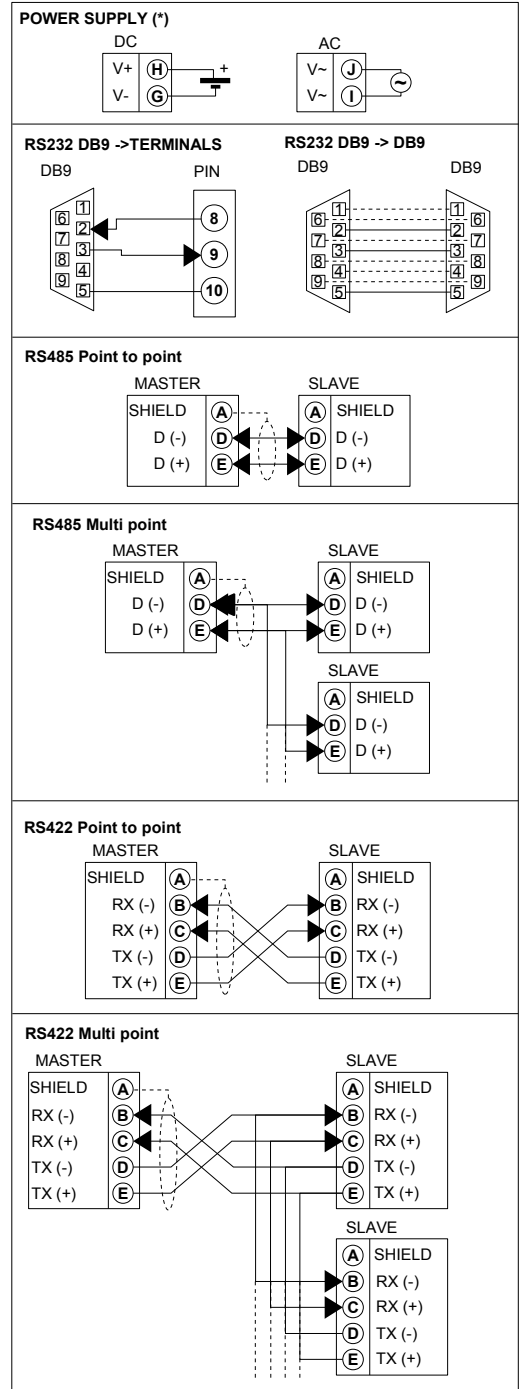

(* Note: for UL installation the device must be powered using a power supply unit classified NEC class 2 or SELV

ISOLATION STRUCTURE

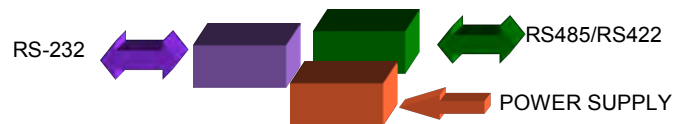

HOW TO ORDER

In phase of order it is necessary to specify the type of interface (RS485 or RS422) and, if required, the 24Vac power supply option.

DAT 3580 / **2W** / **24**

Type of interface:
2W: RS-485 (2 wires)
4W: RS-422 (4 wires)

AC power supply option:
24 : 24Vac (18+30Vac)

■ = Requested
□ = Optional