

User Guide – CANopen protocol

DAT 7016

PROFILE DESCRIPTION

- EDS file:

DAT7016.eds

- Application layer:

CiA DS 301 Version 4.02

- Device Profile:

CiA DS 401 Version 2.1

- Transmit PDO supported :1

- Receive PDO supported: 0

DIP-SWITCH CONFIGURATION

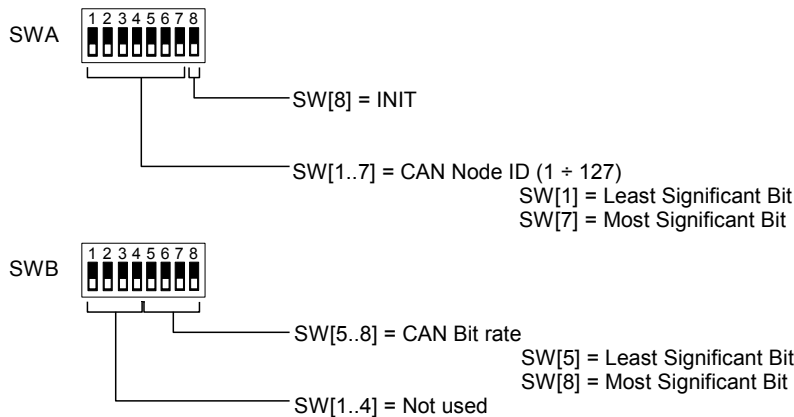

THE OBJECT DICTIONARY (OD)

The Object Dictionary is the part of the device profile wherein are grouped the objects that have an influence on the device behaviour (application objects, communication objects and state objects) .The structure of the Object Dictionary is predefined as in Draft Standard CiA301.

How to read the Object Dictionary table present in this document.

Index	N° Sub-index	Name	Description	Object type	Default value	Access
-------	--------------	------	-------------	-------------	---------------	--------

Index: 16 bit number expressed in Hex format used to address the object inside the OD;

Sub-index: 8 bit number expressed in Hex format used to indicate and address the sub parts of an object;

Name: Defines which is the name of the object inside the OD;

Description: Text strings that describe what is the function of the object;

Object type: Indicates what is the data type of the object (Unsigned 32, Boolean, etc..).

Default value: Indicates what is the default value for an object.

Access: Indicates what is the type of access designed for an object:

RO: indicates an object that could only be read;

RW: indicates an object that could be read and written

---: indicates that the object is a complex object addressed by Sub-index.

PROCESS DATA OBJECTS (PDO)

The real time data-transfer is performed by means of the Process Data Object (PDO). The PDO is transmitted only from one Producer to one or more customer; the data capability of a PDO is included between 1 and 8 bytes.

There are two kinds of PDOs: the first is used for data transmission (TPDO) and the second is used for data reception (RPDO). The PDOs are described by the communication parameters and the mapping parameters. The communication parameters define the communication capability of the PDO; the mapping parameters define the content of PDO. Data type and mapping of the application objects into a PDO is determined by the default structure specified in the Object Dictionary.

The communication parameter is composed of:

- COB-ID;
- Transmission type;
- Inhibit time;
- Event timer.

COB-ID.

The COB-ID is the Connection Object Identifier and contains the unique CAN message Identifier of the object and additional configuration bits. For the PDOs the following 32 bit COB-ID are foreseen.

TPDO1: NODE ID + 0x00000180;

TPDO2: NODE ID + 0x00000280;

TPDO3: NODE ID + 0x00000380;

TPDO4: NODE ID + 0x00000480;

RPDO1: NODE ID + 0x00000200;

RPDO2: NODE ID + 0x00000300;

RPDO3: NODE ID + 0x00000400;

RPDO4: NODE ID + 0x00000500.

The NODE ID is the CAN node ID of the device. The range value is from 0x01 (decimal 1) up to 0x7F (decimal 127).

If the first byte is 8 the PDO is not used; if it is 0, the PDO is used.

Transmission Type.

To transmit the PDO the following transmission modes can be used:

- Synchronous Transmission
- Asynchronous Transmission

The value of the parameter " Transmission type" defines how the PDO transmission is performed.

For TPDOs:

Value 0.

The TPDO is synchronous acyclic; it is transmitted after the receiving of a SYNC object when one or more parameters change.

Value 1-240.

The TPDO is synchronous cyclic. It is transmitted after every *n*th SYNC object within the "Synchronous Window Length" (object 0x1007). The value *n* is the value of the Transmission Type.

NOTE: The Communication Cycle Period object (0x1006) express the time between two SYNC and must have the same value or a bigger value of the Synchronous Window Length.

Value 255.

The TPDO is asynchronous and it is transmitted in function of the parameter "Event timer".

For RPDOs:

Value 0-240.

The RPDO is synchronous and the actual value of transmission type is not relevant because the RPDO is processed on reception of the next SYNC object.

Value 255.

The RPDO is asynchronous and it is processed by the node as soon as the PDO arrives.

Inhibit Time.

This is the time within the PDO is not transmitted. The PDO is transmitted only when the time expires.

Event Timer.

The PDO is transmitted on a fixed time base.

FUNCTIONAL DIAGRAM FOR ANALOGUE INPUTS TRANSMISSION

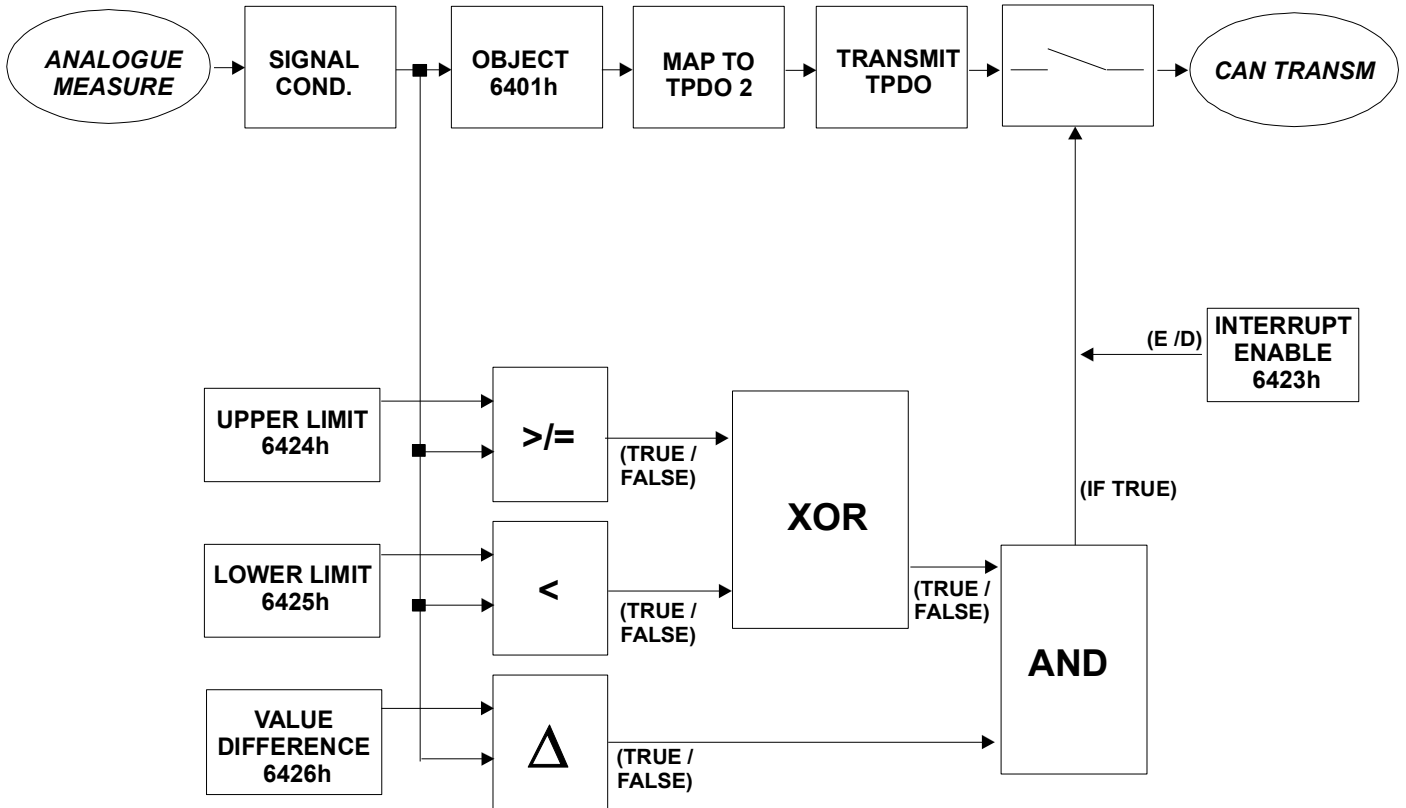

INTERRUPT TRIGGERING TPDO TRANSMISSION.

The analogue signals are processed and transferred to the object 6401h. The data of this object are moved to the TPDO in function of the mapping parameters set in the object 1A01h. The communication parameters of TPDO are defined in the object 1801h .

In the same time the analogue measure is checked with the values contained in the objects 6424h (upper limit), 6425h (lower limit) and 6426h (delta).

The system execute the boolean operation XOR between the object 6424h (true if the input measure is greater or equal the pre-set values of the object) and the object 6425h (true if the input measure is lower the pre-set values of the object) and successively execute the boolean operation AND between the result of the XOR and the object 6426h (true if the input measure rises or falls above or below of the delta value respect to the last communicated value).

If the result of the operation AND is true, the transmission of the TPDO is performed only if the object 6423h has been enabled (value set as 255).

DAT7016 OBJECT DICTIONARY

Index	N° Sub-index	Name	Description	Object type	Default value	Access
0x1000	0	Device Type	Identifies the type of device (analog input) and its Device Profile (CiA 401)	Unsigned 32	0x00040191	RO
0x1001	0	Error register	Register used to monitor eventual internal errors	Unsigned 8	0x00	RO
0x1002	0	Manufacturer status register	Status register	Unsigned 32	0x00000000	RO
0x1003	2	Predefined error field	Contains the list of the recent errors	Array	-----	----
	Sub Index 0	Number of errors	Contains the number of errors occurred	Unsigned 8	0x00	RW
	Sub Index 1	Standard error field 1	Stores the recent errors occurred	Unsigned 32	0x00000000	RO
0x1005	0	SYNC COB-ID	Defines the COB-ID of the Synchronism Object consumed	Unsigned 32	0x00000080	RW
0x1006	0	Communication cycle period	Defines the SYNC interval and it is expressed as μ s	Unsigned 32	0x00000000	RW
0x1007	0	Synchronous window length	Defines the time window expressed as μ s to transmit the synchronous PDO after the SYNC object	Unsigned 32	0x00000000	RW
0x1008	0	Manufacturer device name	Contains the device's name	Visible String	"DAT 7016"	RO
0x1009	0	Manufacturer hardware Version	Indicates the hardware version of the device	Visible String	"1.00"	RO
0x100A	0	Manufacturer software Version	Indicates the version of the device's firmware	Visible String	"2.10"	RO
0x1010	2	Store parameters	Supports the saving of the parameters	Array	-----	----
	Sub Index 0	Max sub-index number	Contains the number of sub index supported	Unsigned 8	0x01	RO
	Sub Index 1	Save all parameters	Saves all the parameters	Unsigned 32	0x00000000	RW
Write the value 65766173 Hex, 1702257011 Decimal (ASCII "save") in sub-index to save data.						
0x1011	2	Restore default	Restore the default values of the parameters	Array	-----	----
	Sub Index 0	Max sub-index number	Contains the number of sub index supported	Unsigned 8	0x01	RO
	Sub Index 1	Restore all parameters	Restores all the parameters	Unsigned 32	0x00000000	RW
Write the value 64616F6C Hex, 1684107116 Decimal (ASCII "load") in sub-index to restore data. Type of reset caused at the restore of default: -restore of sub index 1 : Node reset						

Index	N° Sub-index	Name	Description	Object type	Default value	Access
0x1014	0	COB-ID Emergency Object (EMCY)	Defines the COB-ID of the Emergency Object	Unsigned 32	Node ID + 0x80	RW
0x1015	0	Inhibit time (EMCY)	Defines the inhibit time for the Emergency Object (multiple of 100 µs)	Unsigned 32	0x00000000	RW
0x1016	2	Consumer heartbeat time	Defines the heartbeat cycle time (multiple of 1 ms)	Array	-----	----
	Sub Index 0	Max sub-index number	Contains the number of sub index supported	Unsigned 8	0x01	RO
	Sub Index 1	Consumer heartbeat time	Heartbeat time	Unsigned 32	0x00000000	RW
0x1017	0	Producer heartbeat time	Defines the heartbeat cycle time (multiple of 1 ms)	Unsigned 16	0x00000000	RW
0x1018	5	Identity	Contains the general information about the device	Record	-----	----
	Sub Index 0	Max sub-index number	Contains the number of sub index supported	Unsigned 8	0x04	RO
	Sub Index 1	Vendor ID	Datexel s.r.l. Unique code	Unsigned 32	0x000003CD	RO
	Sub Index 2	Product code	DAT7016 ID code	Unsigned 32	0x00000004	RO
	Sub Index 3	Revision number	Revision number	Unsigned 32	0x00000000	RO
	Sub Index 4	Serial number	Serial number code	Unsigned 32	0x00000000	RO
0x1029	2	Error behaviour	Defines the behaviour of the device in case of error encountered	Array	-----	----
	Sub Index 0	Max sub-index number	Contains the number of error classes	Unsigned 8	0x01	RO
	Sub Index 1	Communication error	Defines the device condition for a communication error	Unsigned 8	0x00	RW
0x1200	3	Server SDO parameters	Describes the SDO communication channel for the node	Array	-----	----
	Sub Index 0	Max sub-index number	Contains the number of sub-index supported	Unsigned 8	0x02	RO
	Sub Index 1	COB ID Client to Server (Receive SDO)	Defines the COB ID in case of receiving SDO	Unsigned 32	Node ID + 0x600	RO
	Sub Index 2	COB ID Server to Client (Transmit SDO)	Defines the COB ID in case of transmitting SDO	Unsigned 32	Node ID + 0x580	RO
0x1801	5	2nd TDO communication parameters	List of the parameters of the 2 nd TPDO	Record	-----	----
	Sub Index 0	Max sub-index number	Contains the number of sub-index supported	Unsigned 8	0x04	RO
	Sub Index 1	COB ID	Defines the COB ID of the PDO	Unsigned 32	Node ID + 0x280	RW
	Sub Index 2	Transmission type	Defines the transmission type for the TPDO	Unsigned 8	0xFF	RW
	Sub Index 3	Inhibit timer	Defines the delay to transmit the next PDO (multiple of 100 µs)	Unsigned 16	0x0000	RW
	Sub Index 5	Event timer	Transmits the PDO when the timer is expired (multiple of 1 ms)	Unsigned 16	0x0000	RW
0x1A01	5	2nd TPDO mapping parameters	List of mapping parameters of the 2 nd TPDO	Array	-----	----
	Sub Index 0	Max sub-index number	Contains the number of sub-index supported	Unsigned 8	0x04	RW
	Sub Index 1	Mapped Object 1	Defines the 1 st object mapped into TPDO	Unsigned 32	0x64010110	RW
	Sub Index 2	Mapped Object 2	Defines the 2 nd object mapped into TPDO	Unsigned 32	0x64010210	RW
	Sub Index 3	Mapped Object 3	Defines the 3 rd object mapped into TPDO	Unsigned 32	0x64010310	RW
	Sub Index 4	Mapped Object 4	Defines the 4 th object mapped into TPDO	Unsigned 32	0x64010410	RW

Index	N° Sub-index	Name	Description	Object type	Default value	Access																																	
0x2101	0	Can Node ID	Defines which is the default CAN node number of the device	Unsigned 8	0x7F	RO																																	
	Values available: from Dec.1 (0x01) up to Dec 127 (0x7F).																																						
0x2102	0	Can bit rate	Defines which is the default bit rate value	Unsigned 8	0x03	RO																																	
	Decimal and Hex value to select the Bit rate parameter.																																						
			<table border="1"> <thead> <tr> <th>Bit rate</th> <th>Value (Dec)</th> <th>Value (Hex)</th> </tr> </thead> <tbody> <tr> <td>10 Kbps</td> <td>0</td> <td>0x00</td> </tr> <tr> <td>20 Kbps</td> <td>1</td> <td>0x01</td> </tr> <tr> <td>50 Kbps</td> <td>2</td> <td>0x02</td> </tr> <tr> <td>125 Kbps</td> <td>3</td> <td>0x03</td> </tr> <tr> <td>250 Kbps</td> <td>4</td> <td>0x04</td> </tr> <tr> <td>500 Kbps</td> <td>5</td> <td>0x05</td> </tr> <tr> <td>800 Kbps</td> <td>6</td> <td>0x06</td> </tr> <tr> <td>1 Mbps</td> <td>7</td> <td>0x07</td> </tr> </tbody> </table>	Bit rate	Value (Dec)	Value (Hex)	10 Kbps	0	0x00	20 Kbps	1	0x01	50 Kbps	2	0x02	125 Kbps	3	0x03	250 Kbps	4	0x04	500 Kbps	5	0x05	800 Kbps	6	0x06	1 Mbps	7	0x07									
Bit rate	Value (Dec)	Value (Hex)																																					
10 Kbps	0	0x00																																					
20 Kbps	1	0x01																																					
50 Kbps	2	0x02																																					
125 Kbps	3	0x03																																					
250 Kbps	4	0x04																																					
500 Kbps	5	0x05																																					
800 Kbps	6	0x06																																					
1 Mbps	7	0x07																																					
0x2107	5	Sensor type selection	Contains the programming of the Analog Input Channels	Array	-----	----																																	
	Sub Index 0	Max sub-index number	Contains the number of sub-index supported	Unsigned 8	0x04	RO																																	
	Sub Index 1	CH1 sensor type	Programming of Input Channel 1	Unsigned 8	0x01	RW																																	
	Sub Index 2	CH2 sensor type	Programming of Input Channel 2	Unsigned 8	0x01	RW																																	
	Sub Index 3	CH3 sensor type	Programming of Input Channel 3	Unsigned 8	0x01	RW																																	
	Sub Index 4	CH4 sensor type	Programming of Input Channel 4	Unsigned 8	0x01	RW																																	
	Decimal and Hex values to select the type of the input sensor.																																						
			<table border="1"> <thead> <tr> <th>Input type</th> <th>Value (Dec)</th> <th>Value (Hex)</th> </tr> </thead> <tbody> <tr> <td>Input not used</td> <td>0</td> <td>0x00</td> </tr> <tr> <td>+/- 100 mV</td> <td>1</td> <td>0x01</td> </tr> <tr> <td>Thermocouple J</td> <td>24</td> <td>0x18</td> </tr> <tr> <td>Thermocouple K</td> <td>25</td> <td>0x19</td> </tr> <tr> <td>Thermocouple T</td> <td>26</td> <td>0x1A</td> </tr> <tr> <td>Thermocouple E</td> <td>27</td> <td>0x1B</td> </tr> <tr> <td>Thermocouple R</td> <td>28</td> <td>0x1C</td> </tr> <tr> <td>Thermocouple S</td> <td>29</td> <td>0x1D</td> </tr> <tr> <td>Thermocouple B</td> <td>30</td> <td>0x1E</td> </tr> <tr> <td>Thermocouple N</td> <td>31</td> <td>0x1F</td> </tr> </tbody> </table>	Input type	Value (Dec)	Value (Hex)	Input not used	0	0x00	+/- 100 mV	1	0x01	Thermocouple J	24	0x18	Thermocouple K	25	0x19	Thermocouple T	26	0x1A	Thermocouple E	27	0x1B	Thermocouple R	28	0x1C	Thermocouple S	29	0x1D	Thermocouple B	30	0x1E	Thermocouple N	31	0x1F			
Input type	Value (Dec)	Value (Hex)																																					
Input not used	0	0x00																																					
+/- 100 mV	1	0x01																																					
Thermocouple J	24	0x18																																					
Thermocouple K	25	0x19																																					
Thermocouple T	26	0x1A																																					
Thermocouple E	27	0x1B																																					
Thermocouple R	28	0x1C																																					
Thermocouple S	29	0x1D																																					
Thermocouple B	30	0x1E																																					
Thermocouple N	31	0x1F																																					

Index	N° Sub-index	Name	Description	Object type	Default value	Access
0x6401	5	16 bit Input Channel Measure	Contains the measures of the Analog Input Channels	Array	-----	----
	Sub Index 0	Max sub-index number	Contains the number of sub-index supported	Unsigned 8	0x04	RO
	Sub Index 1	CH1 measure	Shows the measure of the Input Channel 1	Integer 16	-----	RO
	Sub Index 2	CH2 measure	Shows the measure of the Input Channel 2	Integer 16	-----	RO
	Sub Index 3	CH3 measure	Shows the measure of the Input Channel 3	Integer 16	-----	RO
	Sub Index 4	CH4 measure	Shows the measure of the Input Channel 4	Integer 16	-----	RO
0x6423	0	16 bits Analogue Global Interrupt Enable	Enables / Disable globally the interrupt behaviour	Unsigned 8	0	RW
	Value 0: object disable (no analog input activates the interrupt). Value 255: object enabled (one or more analog input can activate the interrupt).					
0x6424	5	16 bits Analogue Interrupt Upper limits	Contains the upper limits for the analog input channels	Array	-----	----
	Sub Index 0	Max sub-index number	Contains the number of sub-index supported	Unsigned 8	0x04	RO
	Sub Index 1	CH1 Interrupt Upper limit	Upper limit of the Channel 1	Integer 16	0x0000	RW
	Sub Index 2	CH2 Interrupt Upper limit	Upper limit of the Channel 2	Integer 16	0x0000	RW
	Sub Index 3	CH3 Interrupt Upper limit	Upper limit of the Channel 3	Integer 16	0x0000	RW
	Sub Index 4	CH4 Interrupt Upper limit	Upper limit of the Channel 4	Integer 16	0x0000	RW
This object works only if the Object 0x6423 has been enabled. The interrupt is triggered when the input measure rise above or is equal to the setted value.						
0x6425	5	16 bits Analogue Interrupt Lower limits	Contains the lower limits for the analog input channels	Array	-----	----
	Sub Index 0	Max sub-index number	Contains the number of sub-index supported	Unsigned 8	0x04	RO
	Sub Index 1	CH1 Interrupt Lower limit	Lower limit of the Channel 1	Integer 16	0x0000	RW
	Sub Index 2	CH2 Interrupt Lower limit	Lower limit of the Channel 2	Integer 16	0x0000	RW
	Sub Index 3	CH3 Interrupt Lower limit	Lower limit of the Channel 3	Integer 16	0x0000	RW
	Sub Index 4	CH4 Interrupt Lower limit	Lower limit of the Channel 4	Integer 16	0x0000	RW
This object works only if the Object 0x6423 has been enabled. The interrupt is triggered when the input measure falls below the setted value.						
0x6426	5	16 bits Analogue Interrupt Delta	Contains the delta values for the analog input channels	Array	-----	----
	Sub Index 0	Max sub-index number	Contains the number of sub-index supported	Unsigned 8	0x04	RO
	Sub Index 1	CH1 Delta limit	Delta value for the Channel 1	Integer 16	0x000A	RW
	Sub Index 2	CH2 Delta limit	Delta value for the Channel 2	Integer 16	0x000A	RW
	Sub Index 3	CH3 Delta limit	Delta value for the Channel 3	Integer 16	0x000A	RW
	Sub Index 4	CH4 Delta limit	Delta value for the Channel 4	Integer 16	0x000A	RW
This object works only if the Object 0x6423 has been enabled. The interrupt is triggered when the input rises or falling above or below the last communicated value.						

