

User Guide – CANopen protocol

DAT 7188

PROFILE DESCRIPTION

- EDS file:

DAT7188.eds

- Application layer:

CiA DS 301 Version 4.02

- Device Profile:

CiA DS 401 Version 2.1

- Transmit PDO supported :4

- Receive PDO supported: 1

DIP-SWITCH CONFIGURATION

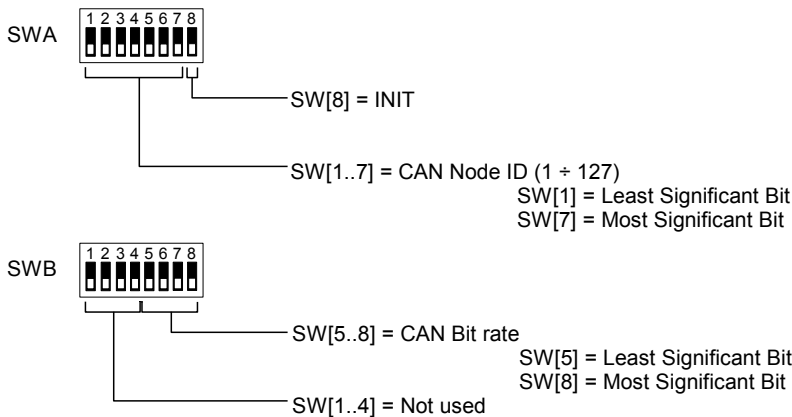

THE OBJECT DICTIONARY (OD)

The Object Dictionary is the part of the device profile wherein are grouped the objects that have an influence on the device behaviour (application objects, communication objects and state objects). The structure of the Object Dictionary is predefined as in Draft Standard CiA301.

How to read the Object Dictionary table present in this document.

Index	N° Sub-index	Name	Description	Object type	Default value	Access
-------	--------------	------	-------------	-------------	---------------	--------

Index: 16 bit number expressed in Hex format used to address the object inside the OD;

Sub-index: 8 bit number expressed in Hex format used to indicate and address the sub parts of an object;

Name: Defines which is the name of the object inside the OD;

Description: Text strings that describe what is the function of the object;

Object type: Indicates what is the data type of the object (Unsigned 32, Boolean, etc..).

Default value: Indicates what is the default value for an object.

Access: Indicates what is the type of access designed for an object:

RO: indicates an object that could only be read;

RW: indicates an object that could be read and written

---: indicates that the object is a complex object addressed by Sub-index.

PROCESS DATA OBJECTS (PDO)

The real time data-transfer is performed by means of the Process Data Object (PDO). The PDO is transmitted only from one Producer to one or more customer; the data capability of a PDO is included between 1 and 8 bytes.

There are two kinds of PDOs: the first is used for data transmission (TPDO) and the second is used for data reception (RPDO). The PDOs are described by the communication parameters and the mapping parameters. The communication parameters define the communication capability of the PDO; the mapping parameters define the content of PDO. Data type and mapping of the application objects into a PDO is determined by the default structure specified in the Object Dictionary.

The communication parameter is composed of:

- COB-ID;
- Transmission type;
- Inhibit time;
- Event timer.

COB-ID.

The COB-ID is the Connection Object Identifier and contains the unique CAN message Identifier of the object and additional configuration bits. For the PDOs the following 32 bit COB-ID are foreseen.

TPDO1: NODE ID + 0x00000180;

TPDO2: NODE ID + 0x00000280;

TPDO3: NODE ID + 0x00000380;

TPDO4: NODE ID + 0x00000480;

RPDO1: NODE ID + 0x00000200;

RPDO2: NODE ID + 0x00000300;

RPDO3: NODE ID + 0x00000400;

RPDO4: NODE ID + 0x00000500.

The NODE ID is the CAN node ID of the device. The range value is from 0x01 (decimal 1) up to 0x7F (decimal 127).

If the first byte is 8 the PDO is not used; if it is 0, the PDO is used.

Transmission Type.

To transmit the PDO the following transmission modes can be used:

- Synchronous Transmission
- Asynchronous Transmission

The value of the parameter " Transmission type" defines how the PDO transmission is performed.

For TPDOs:

Value 0.

The TPDO is synchronous acyclic; it is transmitted after the receiving of a SYNC object when one or more parameters change.

Value 1-240.

The TPDO is synchronous cyclic. It is transmitted after every *n*th SYNC object within the "Synchronous Window Length" (object 0x1007). The value *n* is the value of the Transmission Type.

NOTE: The Communication Cycle Period object (0x1006) express the time between two SYNC and must have the same value or a bigger value of the Synchronous Window Length.

Value 255.

The TPDO is asynchronous and it is transmitted in function of the parameter "Event timer".

For RPDOs:

Value 0-240.

The RPDO is synchronous and the actual value of transmission type is not relevant because the RPDO is processed on reception of the next SYNC object.

Value 255.

The RPDO is asynchronous and it is processed by the node as soon as the PDO arrives.

Inhibit Time.

This is the time within the PDO is not transmitted. The PDO is transmitted only when the time expires.

Event Timer.

The PDO is transmitted on a fixed time base.

FUNCTIONAL DIAGRAM FOR DIGITAL INPUTS TRANSMISSION

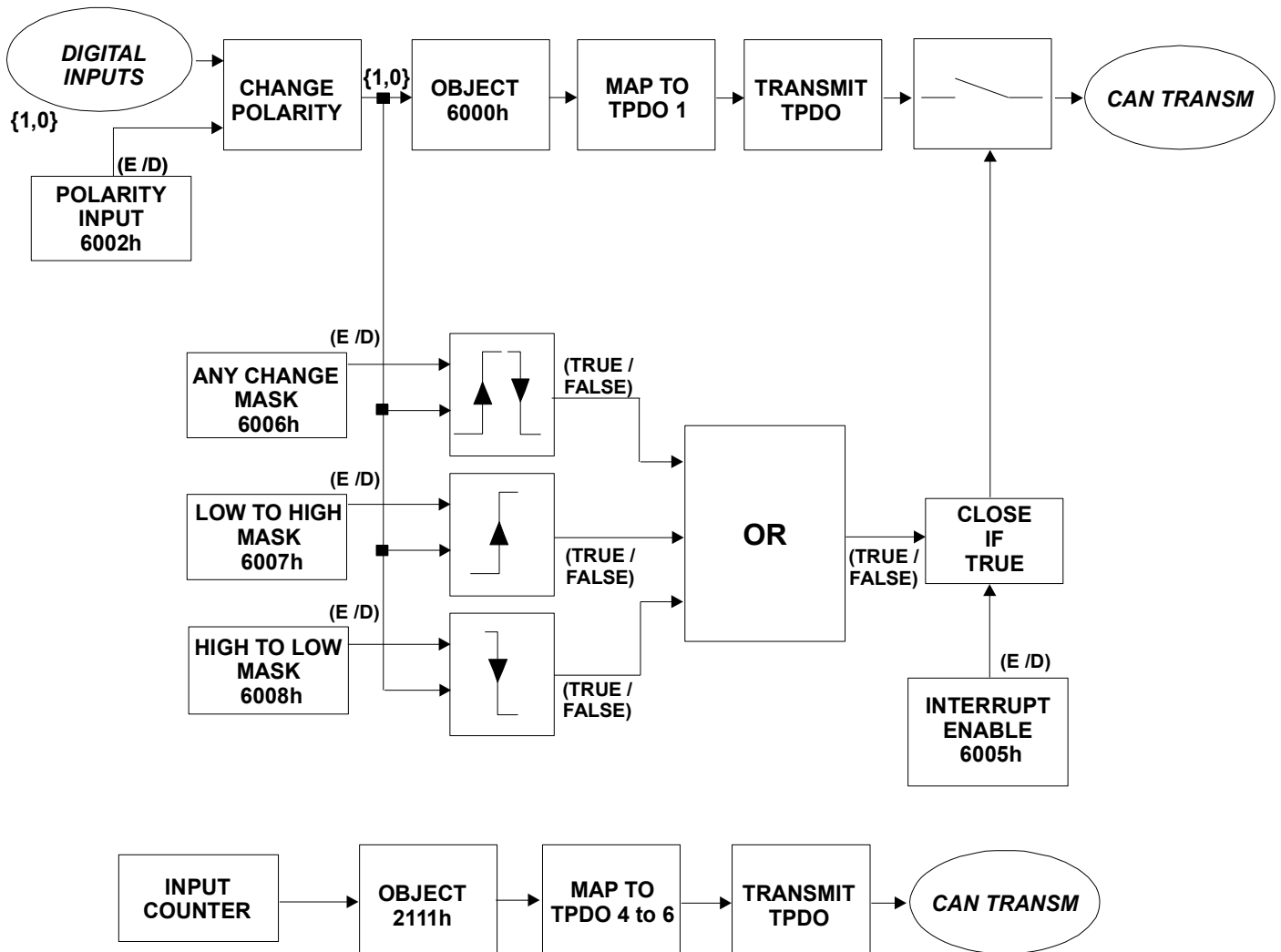

INTERRUPT TRIGGERING TPDO TRANSMISSION.

The digital inputs are processed and transferred to the object 6000h. The data of this object are moved to the 1st TPDO in function of the mapping parameters set in the objects 1A00h. The communication parameters of TPDO are defined in the objects 1800h.

The system executes the boolean operation OR between the values of the masks contained in the objects 6006h (any change mask), 6007h (low to high mask) and 6008h (high to low mask).

If the result of the operation OR is true, the transmission of the TPDO is performed only if the object 6005h has been enabled (value set as 1).

When the digital inputs change to the logic state 1, the associated counter mapped into the object 2111h is incremented.

The data of this object are moved to the TPDOs in function of the mapping parameters set in the objects from 1801h up to 1803h. The communication parameters of TPDOs are defined in the objects from 1A01h up to 1A03h.

To reset the value of the counter write 0 in the SubIndex of the counter selected in the object 2111h.

FUNCTIONAL DIAGRAM FOR DIGITAL OUTPUTS OPERATION

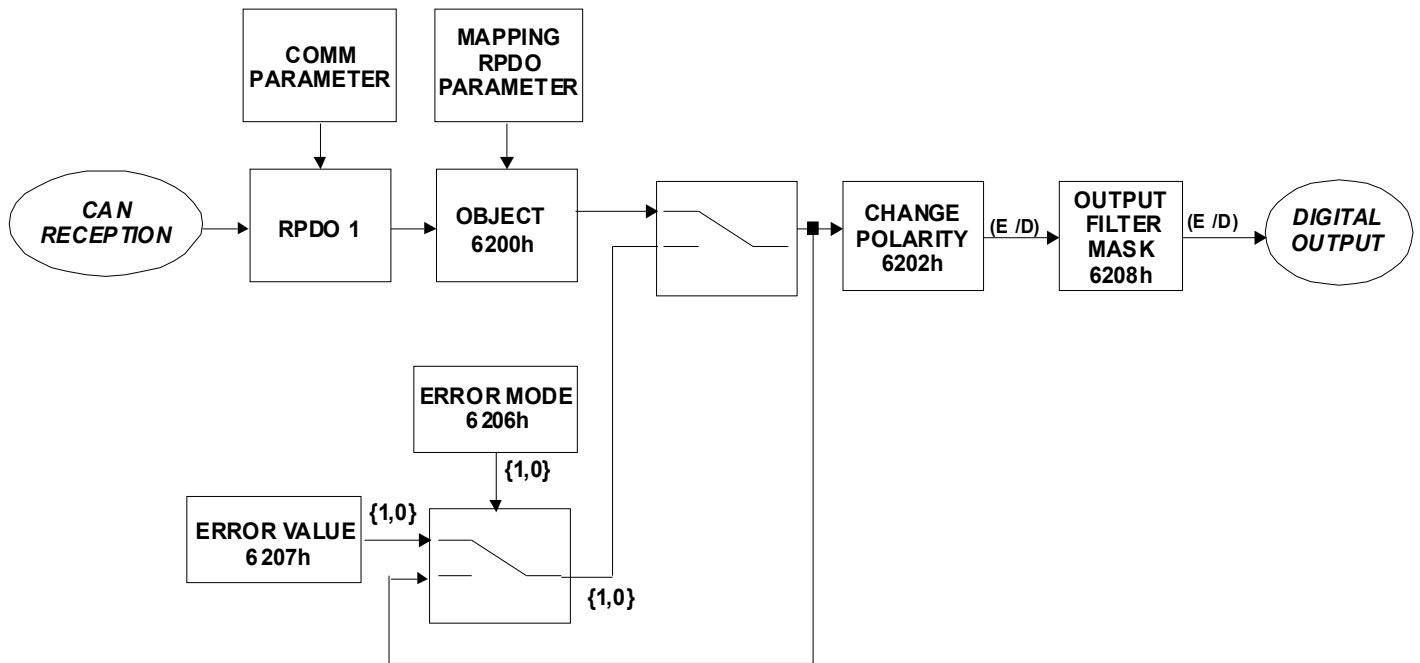

RPDO AND DIGITAL OUTPUTS.

The digital outputs settings coming from the CAN bus are transferred to the 1st RPDO object in function of the mapping parameters set in the object 1600h. The communication parameters of RPDO are defined in the object 1400h.

If there are not internal errors the information is processed as defined in the settings of the object 6202h (Change polarity output) and 6208h (Output filter mask) and transferred to the digital outputs of the device.

If an internal error occurs and if the object 6206h is set as 1 the output values are set as defined from the object 6207h (Error value); if the object 6206h is set as 0 the output value is kept.

DAT7188 OBJECT DICTIONARY

Index	N° Sub-index	Name	Description	Object type	Default value	Access
0x1000	0	Device Type	Identifies the type of device (digital inputs & outputs) and its Device Profile (CiA 401)	Unsigned 32	0x00030191	RO
0x1001	0	Error register	Register used to monitor eventual internal errors	Unsigned 8	0x00	RO
0x1002	0	Manufacturer status register	Status register	Unsigned 32	0x00000000	RO
0x1003	2	Predefined error field	Contains the list of the recent errors	Array	-----	----
	Sub Index 0	Number of errors	Contains the number of errors occurred	Unsigned 8	0x00	RW
	Sub Index 1	Standard error field 1	Stores the recent errors occurred	Unsigned 32	0x00000000	RO
0x1005	0	SYNC COB-ID	Defines the COB-ID of the Synchronism Object consumed	Unsigned 32	0x00000080	RW
0x1006	0	Communication cycle period	Defines the SYNC interval and it is expressed as μ s	Unsigned 32	0x00000000	RW
0x1007	0	Synchronous window length	Defines the time window expressed as μ s to transmit the synchronous PDO after the SYNC object	Unsigned 32	0x00000000	RW
0x1008	0	Manufacturer device name	Contains the device's name	Visible String	"DAT 7188"	RO
0x1009	0	Manufacturer hardware Version	Indicates the hardware version of the device	Visible String	"1.00"	RO
0x100A	0	Manufacturer software Version	Indicates the version of the device's firmware	Visible String	"2.10"	RO
0x1010	5	Store parameters	Supports the saving of the parameters	Array	-----	----
	Sub Index 0	Max sub-index number	Contains the number of sub index supported	Unsigned 8	0x02	RO
	Sub Index 1	Save all parameters	Saves all the parameters	Unsigned 32	0x00000000	RW
Write the value 65766173 Hex, 1702257011 Decimal (ASCII "save") in sub-index to save data.						
0x1011	5	Restore default	Restore the default values of the parameters	Array	-----	----
	Sub Index 0	Max sub-index number	Contains the number of sub index supported	Unsigned 8	0x02	RO
	Sub Index 1	Restore all parameters	Restores all the parameters	Unsigned 32	0x00000000	RW
Write the value 64616F6C Hex, 1684107116 Decimal (ASCII "load") in sub-index to restore data. Type of reset caused at the restore of default: -restore of sub index 1 : Node reset						

Index	N° Sub-index	Name	Description	Object type	Default value	Access
0x1014	0	COB-ID Emergency Object (EMCY)	Defines the COB-ID of the Emergency Object	Unsigned 32	Node ID + 0x80	RW
0x1015	0	Inhibit time (EMCY)	Defines the inhibit time for the Emergency Object (multiple of 100 µs)	Unsigned 32	0x00000000	RW
0x1016	2	Consumer heartbeat time	Defines the heartbeat cycle time (multiple of 1 ms)	Array	-----	----
	Sub Index 0	Max sub-index number	Contains the number of sub index supported	Unsigned 8	0x01	RO
	Sub Index 1	Consumer heartbeat time	Heartbeat time	Unsigned 32	0x00000000	RW
0x1017	0	Producer heartbeat time	Defines the heartbeat cycle time (multiple of 1 ms)	Unsigned 16	0x0000	RW
0x1018	5	Identity	Contains the general information about the device	Record	-----	----
	Sub Index 0	Max sub-index number	Contains the number of sub index supported	Unsigned 8	0x04	RO
	Sub Index 1	Vendor ID	Datexel s.r.l. Unique code	Unsigned 32	0x000003CD	RO
	Sub Index 2	Product code	DAT7188 ID code	Unsigned 32	0x00000006	RO
	Sub Index 3	Revision number	Revision number	Unsigned 32	0x00000000	RO
	Sub Index 4	Serial number	Serial number code	Unsigned 32	0x00000000	RO
0x1029	2	Error behaviour	Defines the behaviour of the device in case of error encountered	Array	-----	----
	Sub Index 0	Max sub-index number	Contains the number of error classes	Unsigned 8	0x01	RO
	Sub Index 1	Communication error	Defines the device condition for a communication error	Unsigned 8	0x00	RW
0x1200	3	Server SDO parameters	Describes the SDO communication channel for the node	Array	-----	----
	Sub Index 0	Max sub-index number	Contains the number of sub-index supported	Unsigned 8	0x02	RO
	Sub Index 1	COB ID Client to Server (Receive SDO)	Defines the COB ID in case of receiving SDO	Unsigned 32	Node ID + 0x600	RO
	Sub Index 2	COB ID Server to Client (Transmit SDO)	Defines the COB ID in case of transmitting SDO	Unsigned 32	Node ID + 0x580	RO
0x1400	3	1st RPDO communication parameters	List of the parameters of the 1 st RPDO	Record	-----	----
	Sub Index 0	Max sub-index number	Contains the number of sub-index supported	Unsigned 8	0x02	RO
	Sub Index 1	COB ID	Defines the COB ID of the PDO	Unsigned 32	Node ID + 0x200	RO
	Sub Index 2	Transmission type	Defines the transmission type for the RPDO	Unsigned 8	0xFF	RW
0x1600	2	1st RPDO mapping parameters	List of mapping parameters of the 1 st RPDO	Array	-----	----
	Sub Index 0	Max sub-index number	Contains the number of sub-index supported	Unsigned 8	0x02	RW
	Sub Index 1	Mapped Object 1	Defines the 1 st object mapped into RPDO	Unsigned 32	0x62000108	RW

Index	N° Sub-index	Name	Description	Object type	Default value	Access
0x1800	5	1st TPDO communication parameters	List of the parameters of the 1 st TPDO	Record	-----	----
	Sub Index 0	Max sub-index number	Contains the number of sub-index supported	Unsigned 8	0x05	RO
	Sub Index 1	COB ID	Defines the COB ID of the PDO	Unsigned 32	Node ID + 0x180	RW
	Sub Index 2	Transmission type	Defines the transmission type for the TPDO	Unsigned 8	0xFF	RW
	Sub Index 3	Inhibit timer	Defines the delay to transmit the next PDO (multiple of 100 µs)	Unsigned 16	0x0000	RW
	Sub Index 5	Event timer	Transmits the PDO when the timer is expired (multiple of 1 ms)	Unsigned 16	0x0000	RW
0x1801	5	4th TPDO communication parameters	List of the parameters of the 4 th TPDO	Record	-----	----
	Sub Index 0	Max sub-index number	Contains the number of sub-index supported	Unsigned 8	0x05	RO
	Sub Index 1	COB ID	Defines the COB ID of the PDO	Unsigned 32	Node ID + 0x280	RW
	Sub Index 2	Transmission type	Defines the transmission type for the TPDO	Unsigned 8	0xFF	RW
	Sub Index 3	Inhibit timer	Defines the delay to transmit the next PDO (multiple of 100 µs)	Unsigned 16	0x0000	RW
	Sub Index 5	Event timer	Transmits the PDO when the timer is expired (multiple of 1 ms)	Unsigned 16	0x0000	RW
0x1802	5	5th TPDO communication parameters	List of the parameters of the 5 th TPDO	Record	-----	----
	Sub Index 0	Max sub-index number	Contains the number of sub-index supported	Unsigned 8	0x05	RO
	Sub Index 1	COB ID	Defines the COB ID of the PDO	Unsigned 32	Node ID + 0x380	RW
	Sub Index 2	Transmission type	Defines the transmission type for the TPDO	Unsigned 8	0xFF	RW
	Sub Index 3	Inhibit timer	Defines the delay to transmit the next PDO (multiple of 100 µs)	Unsigned 16	0x0000	RW
	Sub Index 5	Event timer	Transmits the PDO when the timer is expired (multiple of 1 ms)	Unsigned 16	0x0000	RW
0x1803	5	6th TPDO communication parameters	List of the parameters of the 6 th TPDO	Record	-----	----
	Sub Index 0	Max sub-index number	Contains the number of sub-index supported	Unsigned 8	0x05	RO
	Sub Index 1	COB ID	Defines the COB ID of the PDO	Unsigned 32	Node ID + 0x480	RW
	Sub Index 2	Transmission type	Defines the transmission type for the TPDO	Unsigned 8	0xFF	RW
	Sub Index 3	Inhibit timer	Defines the delay to transmit the next PDO (multiple of 100 µs)	Unsigned 16	0x0000	RW
	Sub Index 5	Event timer	Transmits the PDO when the timer is expired (multiple of 1 ms)	Unsigned 16	0x0000	RW
0x1A00	2	1st TPDO mapping parameters	List of mapped parameters of the 1 st TPDO	Array	-----	----
	Sub Index 0	Number of mapped objects	Contains the number of sub-index supported	Unsigned 8	0x01	RO
	Sub Index 1	Mapped Object 1	Defines the 1 st object mapped into TPDO	Unsigned 32	0x60000108	RW

Index	N° Sub-index	Name	Description	Object type	Default value	Access																												
0x1A01	3	4th TPDO mapping parameters	List of mapped parameters of the 4 th TPDO	Array	-----	----																												
	Sub Index 0	Number of mapped objects	Contains the number of sub-index supported	Unsigned 8	0x02	RO																												
	Sub Index 1	Mapped Object 1	Defines the 1 st object mapped into TPDO	Unsigned 32	0x21110120	RW																												
	Sub Index 2	Mapped Object 2	Defines the 2 nd object mapped into TPDO	Unsigned 32	0x21110220	RW																												
0x1A02	3	5th TPDO mapping parameters	List of mapped parameters of the 5 th TPDO	Array	-----	----																												
	Sub Index 0	Number of mapped objects	Contains the number of sub-index supported	Unsigned 8	0x02	RO																												
	Sub Index 1	Mapped Object 1	Defines the 1 st object mapped into TPDO	Unsigned 32	0x21110320	RW																												
	Sub Index 2	Mapped Object 2	Defines the 2 nd object mapped into TPDO	Unsigned 32	0x21110420	RW																												
0x1A03	3	6th TPDO mapping parameters	List of mapped parameters of the 6 th TPDO	Array	-----	----																												
	Sub Index 0	Number of mapped objects	Contains the number of sub-index supported	Unsigned 8	0x02	RO																												
	Sub Index 1	Mapped Object 1	Defines the 1 st object mapped into TPDO	Unsigned 32	0x21110520	RW																												
	Sub Index 2	Mapped Object 2	Defines the 2 nd object mapped into TPDO	Unsigned 32	0x21110620	RW																												
0x2101	0	Can Node ID	Defines which is the default CAN node number of the device	Unsigned 8	0x7F	RO																												
Values available: from Dec.1 (0x01) up to Dec 127 (0x7F). The values are programmable only from dip switch.																																		
0x2102	0	Can bit rate	Defines which is the default bit rate value	Unsigned 8	0x03	RO																												
Decimal and Hex value to select the Bit rate parameter. The values are programmable only from dip switch.																																		
			<table border="1"> <thead> <tr> <th>Bit rate</th> <th>Value (Dec)</th> <th>Value (Hex)</th> </tr> </thead> <tbody> <tr> <td>10 Kbps</td> <td>0</td> <td>0x00</td> </tr> <tr> <td>20 Kbps</td> <td>1</td> <td>0x01</td> </tr> <tr> <td>50 Kbps</td> <td>2</td> <td>0x02</td> </tr> <tr> <td>125 Kbps</td> <td>3</td> <td>0x03</td> </tr> <tr> <td>250 Kbps</td> <td>4</td> <td>0x04</td> </tr> <tr> <td>500 Kbps</td> <td>5</td> <td>0x05</td> </tr> <tr> <td>800 Kbps</td> <td>6</td> <td>0x06</td> </tr> <tr> <td>1 Mbps</td> <td>7</td> <td>0x07</td> </tr> </tbody> </table>	Bit rate	Value (Dec)	Value (Hex)	10 Kbps	0	0x00	20 Kbps	1	0x01	50 Kbps	2	0x02	125 Kbps	3	0x03	250 Kbps	4	0x04	500 Kbps	5	0x05	800 Kbps	6	0x06	1 Mbps	7	0x07				
Bit rate	Value (Dec)	Value (Hex)																																
10 Kbps	0	0x00																																
20 Kbps	1	0x01																																
50 Kbps	2	0x02																																
125 Kbps	3	0x03																																
250 Kbps	4	0x04																																
500 Kbps	5	0x05																																
800 Kbps	6	0x06																																
1 Mbps	7	0x07																																
0x2111	9	Input Counter Value	Contains the value of 8 input counter available	Array	-----	----																												
	Sub Index 0	Max sub-index number	Contains the number of sub-index supported	Unsigned 8	0x08	RO																												
	Sub Index 1	Input 1 counter	Contains the value of the counter associated to the digital input 1	Unsigned 32	0x00000000	RW																												
	Sub Index 2	Input 2 counter	Contains the value of the counter associated to the digital input 2	Unsigned 32	0x00000000	RW																												
	Sub Index 3	Input 3 counter	Contains the value of the counter associated to the digital input 3	Unsigned 32	0x00000000	RW																												
	Sub Index 4	Input 4 counter	Contains the value of the counter associated to the digital input 4	Unsigned 32	0x00000000	RW																												
	Sub Index 5	Input 5 counter	Contains the value of the counter associated to the digital input 5	Unsigned 32	0x00000000	RW																												
	Sub Index 6	Input 6 counter	Contains the value of the counter associated to the digital input 6	Unsigned 32	0x00000000	RW																												
	Sub Index 7	Input 7 counter	Contains the value of the counter associated to the digital input 7	Unsigned 32	0x00000000	RW																												
	Sub Index 8	Input 8 counter	Contains the value of the counter associated to the digital input 8	Unsigned 32	0x00000000	RW																												

Index	N° Sub-index	Name	Description	Object type	Default value	Access
0x6000	2	Read Input 8 bit	Contains the measure of the Digital Input Channels	Array	-----	----
	Sub Index 0	Max sub-index number	Contains the number of sub-index supported	Unsigned 8	0x01	RO
	Sub Index 1	Digital Inputs 1 to 8	Digital input channel measure	Unsigned 8	0x00	RO
0x6002	2	Polarity Input 8 bit	Contains the settings of the polarity of each single input bit	Array	-----	----
	Sub Index 0	Max sub-index number	Contains the number of sub-index supported	Unsigned 8	0x01	RO
	Sub Index 1	Polarity bit 1 to 8	Digital input polarity settings 0=input not inverted; 1=input inverted	Unsigned 8	0x00	RW
0x6005	0	Global Interrupt Enable Digital	Allows to enable / disable the global interrupt behaviour 0 = global interrupt disabled 255 = global interrupt enabled	Unsigned 8	255	RW
0x6006	2	Interrupt Mask Any Change 8 bit	Defines which input port shall activate an interrupt on positive / negative edge detection	Array	-----	----
	Sub Index 0	Max sub-index number	Contains the number of sub-index supported	Unsigned 8	0x01	RO
	Sub Index 1	Mask bit 1 to 8	Mask bit settings 0=interrupt disable; 1=interrupt enabled	Unsigned 8	0xFF	RW
0x6007	2	Interrupt Mask Low-to-High 8 bit	Defines which input port shall activate an interrupt on positive edge detection	Array	-----	----
	Sub Index 0	Max sub-index number	Contains the number of sub-index supported	Unsigned 8	0x01	RO
	Sub Index 1	Mask bit 1 to 8	Mask bit settings 0=interrupt disable; 1=interrupt enabled	Unsigned 8	0x00	RW
0x6008	2	Interrupt Mask High-to-Low 8 bit	Defines which input port shall activate an interrupt on negative edge detection	Array	-----	----
	Sub Index 0	Max sub-index number	Contains the number of sub-index supported	Unsigned 8	0x01	RO
	Sub Index 1	Mask bit 1 to 8	Mask bit settings 0=interrupt disable; 1=interrupt enabled	Unsigned 8	0x00	RW
0x6200	2	Write Output bits	Contains the programming for the digital outputs bits	Array	-----	----
	Sub Index 0	Max sub-index number	Contains the number of sub-index supported	Unsigned 8	0x01	RO
	Sub Index 1	Digital Outputs 1 to 8	Digital output programming	Unsigned 8	0x00	WO
0x6202	2	Change Polarity Output bits	Contains the settings of the polarity of each single output bit	Array	-----	----
	Sub Index 0	Max sub-index number	Contains the number of sub-index supported	Unsigned 8	0x01	RO
	Sub Index 1	Polarity outputs 1 to 8	Digital outputs polarity settings 0=output not inverted; 1=output inverted	Unsigned 8	0x00	RW
0x6206	2	Error mode outputs 8 bits	Defines the condition of each output bit when an internal error occurs	Array	-----	----
	Sub Index 0	Max sub-index number	Contains the number of sub-index supported	Unsigned 8	0x01	RO
	Sub Index 1	Error mode outputs 1 to 8	Digital output condition 0=output value set as defined in object 6207 1=output value kept	Unsigned 8	0xFF	RW
0x6207	2	Error value outputs 8 bits	Defines the value of each output bit when an internal error occurs	Array	-----	----
	Sub Index 0	Max sub-index number	Contains the number of sub-index supported	Unsigned 8	0x01	RO
	Sub Index 1	Error value outputs 1 to 8	Digital output value 0 = output value set to 0 1 = output value set to 1	Unsigned 8	0x00	RW
0x6208	2	Filter Mask outputs 8 bits	Defines which output port will be set to the received out value	Array	-----	----
	Sub Index 0	Max sub-index number	Contains the number of sub-index supported	Unsigned 8	0x01	RO
	Sub Index 1	Mask outputs 1 to 8	Digital output enabled	Unsigned 8	0xFF	RW

