

RTD to Ethernet 8 channel Isolated  
Phone: +1 561 779 5660 - e-mail: datexel@datexel.com - www.datexel.com

**FEATURES**

- Interface Ethernet 10/100 Base-T, Modbus TCP Server
- 8 input channels isolated in pairs
- Input configurable for 2 wire RTD and Resistance
- Integrated web server for acquiring the status of the analogue inputs via browser
- Remotely programmable
- Connection by removable screw-terminals
- LED signalling for Link/Act Ethernet, power supply
- Galvanic isolation on all the ways
- UL/CE mark
- In compliance to EN-50022 DIN rail mounting



**GENERAL DESCRIPTION**

The device DAT8019 is a Modbus TCP server unit that can convert up to 8 analogue signals applied to the input in engineering units in digital format. The inputs can be connected to 2 wires RTDs or resistance sensors .

**The input channels are electrically isolated in pairs.**

The device guarantees high accuracy and a stable measure versus time and temperature.

In order to ensure the safety plant, the device is equipped with a Watch-Dog Timer system.

The Ethernet interface allows reading and writing in real time the values of the internal registers of the device.

The LEDs of signalling of Ethernet activity and power supply allow a direct monitoring of the system functionality.

The built-in Web Server allows the remote visualization, acquisition of the analogue inputs and the access to the main Ethernet programming parameters. The device is also configurable by the software *Dev9K*, a free IDE developed by DATEXEL.

The connection is made by removable screw-terminals (inputs and power supply) and RJ-45 plug (Ethernet).

The DAT8019 is in compliance with the Directive UL 61010-1 for US market and with the Directive CSA C22.2 No 61010-1 for the Canadian market.

The device realizes a full electrical isolation between the lines, introducing a valid protection against the effects of all ground loops eventually existing in industrial applications. The device is housed in a rough self-extinguishing plastic enclosure which, thanks to its thin profile of 22,5 mm only, allows a high density mounting on EN-50022 standard DIN rail.

**USER INSTRUCTIONS**

Before to install the device, please read the "Installation Instruction" section. To configure the device use the INIT modality (refer to the User Guide of the device).

Connect power supply, Ethernet and analogue inputs as shown in the "Wiring" section. The LEDs state depends on the working condition of the device: see the "Light Signalling" section to verify the device working state. To perform configuration and calibration operations, read the instructions in the User Guide of the device.

To simplify handling or replacing of the device, it is possible to remove the wired terminals even with the device powered.

**TECHNICAL SPECIFICATIONS (Typical @ 25 °C and in the nominal conditions)**

<b>In compliance with Ethernet IEEE 802.3</b>  <b>Network interface</b> Ethernet 10/100Base-T <b>Protocol</b> Modbus TCP <b>Max. cable length</b> 100 meters <b>Number of socket</b> 16			<b>Input Accuracy (1)</b> RTD ±0.2 % f.s. Resistance ±0.2 % f.s.  <b>Linearity (1)</b> RTD ±0.1 % f.s.  <b>RTD excitation current</b> Typical 0.370 mA  <b>Thermal drift (1)</b> Full Scale ± 0.01 %/°C  <b>Sampling time (8 channels)</b> 150 ms  <b>Warm-up time</b> 3 min	<b>POWER SUPPLY</b> Power supply voltage 14 .. 30 Vdc Reverse polarity protection 60 Vdc max Current Consumption 150 mA max  <b>ISOLATION</b> Power Supply / Ethernet 1500 Vac, 50 Hz, 1 min Inputs / Power supply 1500 Vac, 50 Hz, 1 min Inputs / Ethernet 1500 Vac, 50 Hz, 1 min Input / Input 1500 Vac, 50 Hz, 1 min  <b>ENVIRONMENTAL CONDITIONS</b> Operative Temperature -10°C .. +60°C UL Operative Temperature -10°C .. +40°C Storage Temperature -40°C .. +85°C Humidity (not condensed) 0 .. 90 % Maximum Altitude 2000 m Installation Indoor Category of installation II Pollution Degree 2																										
<b>INPUT</b>  <table border="1"> <thead> <tr> <th>Input Type</th> <th>Min</th> <th>Max</th> </tr> </thead> <tbody> <tr> <td><b>RTD 2 wires</b></td> <td></td> <td></td> </tr> <tr> <td>Pt100</td> <td>-200 °C</td> <td>850 °C</td> </tr> <tr> <td>Pt1000</td> <td>-200 °C</td> <td>200 °C</td> </tr> <tr> <td>Ni100</td> <td>-60 °C</td> <td>180 °C</td> </tr> <tr> <td>Ni1000</td> <td>-60 °C</td> <td>150 °C</td> </tr> <tr> <td><b>RES 2 wires</b></td> <td></td> <td></td> </tr> <tr> <td>Low</td> <td>0 Ω</td> <td>500 Ω</td> </tr> <tr> <td>High</td> <td>0 Ω</td> <td>2000 Ω</td> </tr> </tbody> </table>			Input Type	Min	Max	<b>RTD 2 wires</b>			Pt100	-200 °C	850 °C	Pt1000	-200 °C	200 °C	Ni100	-60 °C	180 °C	Ni1000	-60 °C	150 °C	<b>RES 2 wires</b>			Low	0 Ω	500 Ω	High	0 Ω	2000 Ω	<b>CONNECTIONS</b> Ethernet RJ-45 (on terminals side) Inputs/Power Supply Removable screw-terminals  <b>MECHANICAL SPECIFICATIONS</b> Material Self-extinguish plastic IP Code IP20 Wiring wires with diameter 0.8±2.1 mm <sup>2</sup> /AWG 14-18 Tightening Torque 0.5 N m Mounting in compliance with DIN rail standard EN-50022 Weight about 160g
Input Type	Min	Max																												
<b>RTD 2 wires</b>																														
Pt100	-200 °C	850 °C																												
Pt1000	-200 °C	200 °C																												
Ni100	-60 °C	180 °C																												
Ni1000	-60 °C	150 °C																												
<b>RES 2 wires</b>																														
Low	0 Ω	500 Ω																												
High	0 Ω	2000 Ω																												
<b>EMC ( for industrial environments )</b> Immunity EN 61000-6-2 Emission EN 61000-6-4 <b>UL</b> US Standard UL 61010-1 Canadian Standard CSA C22.2 No 61010-1 CCN NRAQ/NRAQ7 Typology Open Type device Classification Industrial Control Equipment File Number E352854																														

(1) Referred to input Span (difference between max. and min. values)

## INSTALLATION INSTRUCTIONS

The device is suitable for fitting to DIN rails in vertical position. For optimum operation and long life follow these instructions:

**When the devices are installed side by side it is necessary to separate them by at least:**

- 10 mm if the UL certification is required.
- 5 mm if the UL certification is not required.

Make sure that sufficient air flow is provided for the device avoiding to place raceways or other objects which could obstruct the ventilation slits. Moreover it is suggested to avoid that devices are mounted above appliances generating heat; their ideal place should be in the lower part of the panel.

Install the device in a place without vibrations.

Moreover it is suggested to avoid routing conductors near power signal cables (motors, induction ovens, inverters, etc...) and to use shielded cable for connecting signals.

## MAPPING MODBUS REGISTERS

Register Position	Description	Access
40002	Firmware [0]	RO
40003	Firmware [1]	RO
40004	Name [0]	R/W
40005	Name [1]	R/W
40007	Node ID	R/W
40011	System Flags	R/W
40013	Watchdog timer	R/W
40031	Input type Channels (1-0)	R/W
40032	Input type Channels (3-2)	R/W
40033	Input type Channels (5-4)	R/W
40034	Input type Channels (7-6)	R/W
40041	Analogue Input (0) - Ch0	RO
40042	Analogue Input (1) - Ch1	RO
40043	Analogue Input (2) - Ch2	RO
40044	Analogue Input (3) - Ch3	RO
40045	Analogue Input (4) - Ch4	RO
40046	Analogue Input (5) - Ch5	RO
40047	Analogue Input (6) - Ch6	RO
40048	Analogue Input (7) - Ch7	RO
40050	Break status	RO

## LIGHT SIGNALLING

LED	COLOUR	STATE	DESCRIPTION
PWR	GREEN	ON	Device powered
		OFF	Device not powered
		BLINK	Watchdog alarm
STS	YELLOW	OFF	Device in RUN modality
		BLINK	Device in INIT modality

## MECHANICAL DIMENSIONS (mm)

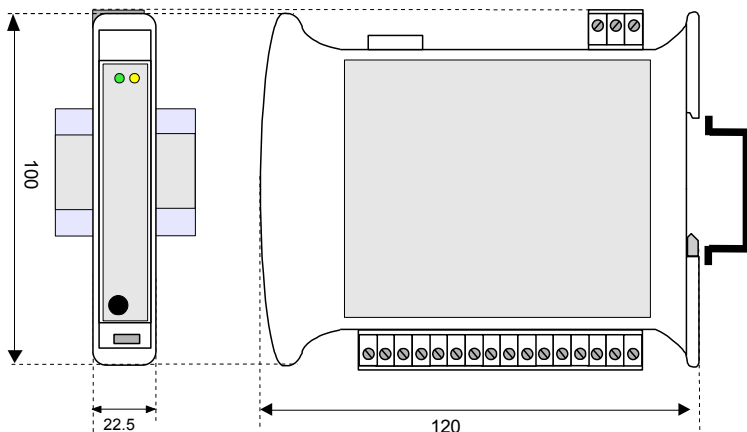

## CONNECTIONS

### POWER SUPPLY (\*)

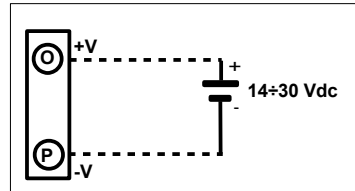

### INIT

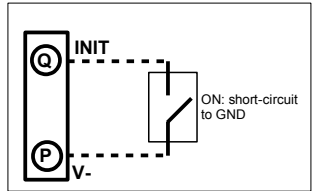

(\*) Note: for UL installation the device must be powered using a power supply unit classified NEC class 2 or SELV and Limited Energy

### ANALOGUE INPUTS

#### RTD, Res

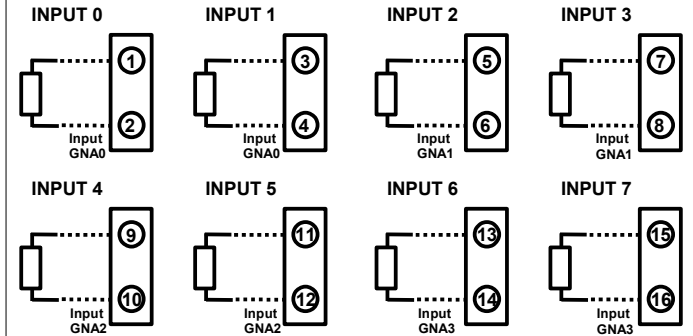

#### NOTES:

Terminals "2" and "4" (neg. reference "GNA0") are internally connected.  
Terminals "6" and "8" (neg. reference "GNA1") are internally connected.  
Terminals "10" and "12" (neg. reference "GNA2") are internally connected.  
Terminals "14" and "16" (neg. reference "GNA3") are internally connected.  
The references "GNA0", "GNA1", "GNA2" and "GNA3" are isolated from each other.

## ISOLATIONS STRUCTURE

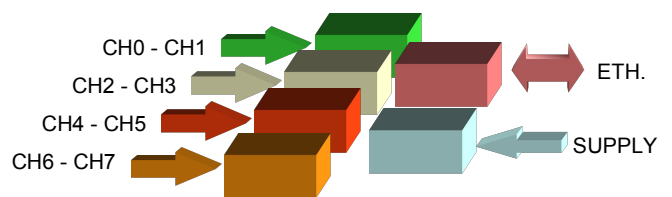

### HOW TO ORDER

" DAT 8019 "

Note: the device is provided with default configuration as:  
IP address : 192.168.1.100  
Modbus address: 1



The symbol reported on the product indicates that the product itself must not be considered as a domestic waste. It must be brought to the authorized recycle plant for the recycling of electrical and electronic waste. For more information contact the proper office in the user's city, the service for the waste treatment or the supplier from which the product has been purchased.