

**FEATURES**

- Configurable input for RTD and resistance
- Configurable output in current or voltage
- Configurable by dip-switch or PC
- High accuracy
- On-field reconfigurable
- Galvanic isolation among the ways
- UL / CE mark
- Suitable for DIN rail mounting in compliance with EN-50022 and EN-50035

**GENERAL DESCRIPTION**

The isolated converter DAT 4531 B is able to measure and linearise the standard RTDs and resistances with 2 or 3 wires cable compensation . In function of programming, the measured values are converted in a current or voltage signal. The device guarantees high accuracy and performances stability both versus time and temperature. The programming is made by the dip-switch located in the window on the side of the enclosure. By means of dip-switches it is possible to select the input type and range and the output type without recalibrate the device. Moreover, by Personal Computer the user can program all of the device's parameters for his own necessity. For all the sensors it is possible to set the cable compensation with 2 or 3 wires. Moreover it is available the option of alarm for signal interruption (burn-out) that allows to set the output value as high or low out of scale . The 1500 Vac galvanic isolation on all ways (input, output and power supply) eliminates the effects of all ground loops eventually existing and allows the use of the converter in heavy environmental conditions found in industrial applications. The DAT 4531 B is in compliance with the Directive UL 61010-1 for US market and with the Directive CSA C22.2 No 61010-1 for the Canadian market. It is housed in a plastic enclosure of 12.5 mm thickness suitable for DIN rail mounting in compliance with EN-50022 and EN-50035 standards.

**USER INSTRUCTIONS**

The connections must be made as shown in the section "Connections". It is possible to configure the converter on field by dip-switch or Personal Computer as shown in the section " Programming ". The configuration by Dip-switches can be made also if the device is powered (note: after the configuration the device takes some seconds to provide the right output measure ).

**TECHNICAL SPECIFICATIONS (Typical at 25 °C and in nominal conditions)**

| INPUT                                |                                 |        |          | OUTPUT                                    |                 |       |          | POWER SUPPLY                    |                |  |
|--------------------------------------|---------------------------------|--------|----------|---|-----------------|-------|----------|---------------------------------|----------------|--|
| Input type                           | Min                             | Max    | Min.Span | Output type                               | Min             | Max   | Min Span |                                 |                |  |
| <b>RTD</b> (2, 3 wires)              |                                 |        |          | Current                                   | 0 mA            | 20 mA | 4 mA     | Power supply voltage            | 18 .. 30 Vdc   |  |
| Pt100                                | -200°C                          | 850°C  | 50°C     | Voltage                                   | 0 V             | 10 V  | 1 V      | Reverse polarity protection     | 60 Vdc max     |  |
| Pt1000                               | -85°C                           | 185°C  | 30°C     | <b>Output resolution</b>                  |                 |       |          | <b>Current consumption</b>      |                |  |
| Ni100                                | -60°C                           | 180°C  | 50°C     | Current                                   | 7 uA            |       |          | Current output                  | 35 mA max.     |  |
| Ni1000                               | -60°C                           | 150°C  | 30°C     | Voltage                                   | 4 mV            |       |          | Voltage output                  | 20 mA max.     |  |
| <b>RES.</b> (2, 3 wires)             |                                 |        |          | <b>Burn-out values</b>                    |                 |       |          | <b>ISOLATION</b>                |                |  |
|                                      | 0 Ω                             | 500 Ω  | 50 Ω     | Max. output value                         | 22 mA or 10.6 V |       |          | Among all the ways              | 1500 Vac,      |  |
|                                      | 0 Ω                             | 2000 Ω | 50 Ω     | Min. output value                         | 0 mA or -0.6 V  |       |          |                                 | 50 Hz, 1 min   |  |
| <b>Accuracy</b> (1)                  |                                 |        |          | <b>Output load Resistance - Rload</b>     |                 |       |          | <b>ENVIRONMENTAL CONDITIONS</b> |                |  |
| RTD                                  | the higher of ±0.1% and ±0.2°C  |        |          | Current output                            | < 500 Ω         |       |          | Operative Temperature           | -20°C .. +60°C |  |
| Low Res.                             | the higher of ±0.1% and ±0.15 Ω |        |          | Voltage output                            | > 10 KΩ         |       |          | UL Operative Temperature        | -10°C .. +60°C |  |
| High Res.                            | the higher of ±0.2% and ± 1 Ω   |        |          | Short circuit current                     | 26 mA max.      |       |          | Storage Temperature             | -40°C.. +85°C  |  |
| <b>Linearity</b> (1)                 |                                 |        |          | <b>Response time (10+ 90%)</b>            |                 |       |          | Humidity (not condensed)        | 0 .. 90 %      |  |
| RTD                                  | ± 0.1 % f.s.                    |        |          |   | about 500 ms    |       |          | Maximum Altitude                | 2000 m         |  |
| <b>Sensor excitation current</b>     |                                 |        |          | <b>MECHANICAL SPECIFICATIONS</b>          |                 |       |          |                                 |                |  |
| RTD,Res                              | 500 uA                          |        |          | Material                                  |                 |       |          |                                 |                | Self-extinguish plastic                                    |
| <b>Line resistance influence</b> (1) |                                 |        |          | IP Code                                   |                 |       |          |                                 |                | IP20   |
| RTD 3 wires                          | 0.05%/Ω (50 Ω max balanced)     |        |          | Wiring                                    |                 |       |          |                                 |                | wires with diameter  |
| <b>Thermal drift</b> (1)             |                                 |        |          | Tightening Torque                         |                 |       |          |                                 |                | 0.8+2.1 mm <sup>2</sup> /AWG 14-18                         |
| Full scale                           | ± 0.01% / °C                    |        |          | Mounting                                  |                 |       |          |                                 |                | 0.8 N m  |
|                                      |                                 |        |          | Weight                                    |                 |       |          |                                 |                | in compliance with DIN rail standard EN-50022 and EN-50035 |
|                                      |                                 |        |          | File Number                               |                 |       |          |                                 |                | about 90 g.  |
|                                      |                                 |        |          | <b>CERTIFICATIONS</b>                     |                 |       |          |                                 |                |  |
|                                      |                                 |        |          | <b>EMC ( for industrial environments)</b> |                 |       |          |                                 |                |  |
|                                      |                                 |        |          | Immunity                                  |                 |       |          |                                 |                | EN 61000-6-2   |
|                                      |                                 |        |          | Emission                                  |                 |       |          |                                 |                | EN 61000-6-4   |
|                                      |                                 |        |          | <b>UL</b>                                 |                 |       |          |                                 |                |  |
|                                      |                                 |        |          | US Standard                               |                 |       |          |                                 |                | UL 61010-1   |
|                                      |                                 |        |          | Canadian Standard                         |                 |       |          |                                 |                | CSA C22.2 No 61010-1                                       |
|                                      |                                 |        |          | CCN                                       |                 |       |          |                                 |                | NRAQ/NRAQ7   |
|                                      |                                 |        |          | Typology                                  |                 |       |          |                                 |                | Open Type device   |
|                                      |                                 |        |          | Classification                            |                 |       |          |                                 |                | Industrial Control Equipment                               |
|                                      |                                 |        |          | File Number                               |                 |       |          |                                 |                | E352854  |

(1)referred to the input Span (difference between max. and min.)

## PROGRAMMING

### CONFIGURATION BY PC

**Notice: before to execute the next operations, check that the drivers of the cable CVPROG in use have been previously installed in the Personal Computer.**

By software DATESOFT from version 2.7 it is possible to:

- set the default programming of the device;
- program the options not available with the dip-switch;  
(burn-out level, CJC offset, trip alarm settings, delay on output, etc...);
- read, in real time, the input and output measures;
- follow the dip-switches configuration wizard.

To configure the device follow the next steps:

- 1) Open the protection plastic label on the front of the device.
- 2) Connect the two plugs of cable CVPROG to the Personal Computer (USB plug) and to the device (uUSB plug).
- 3) Run the software DATESOFT
- 4) Select the COM port in use and click on "Open COM".
- 5) Click on the icon "Program".
- 6) Set the programming data.
- 7) Click on the icon "Write" to send the programming data to the device.

**For information about DATESOFT refer to the software's user guide.**

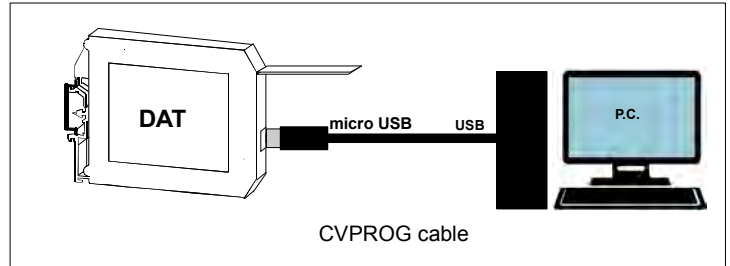

### CONFIGURATION BY DIP-SWITCHES

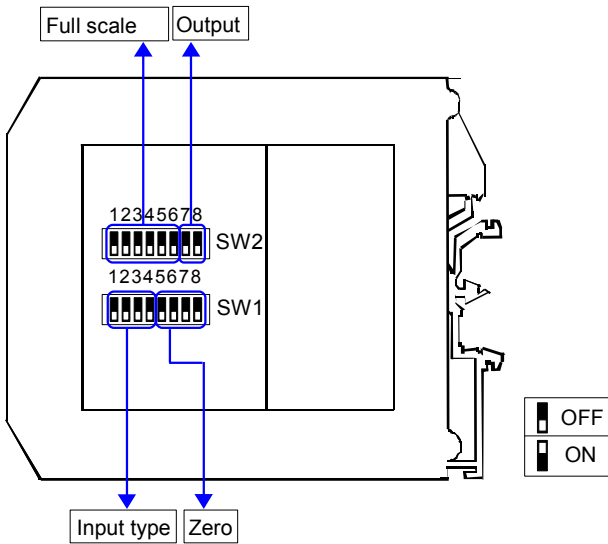

- 1) Open the suitable door on the side of the device.
- 2) Set the input type by the dip-switch SW1 [1..4] (see TAB.1)
- 3) Set the minimum input scale value (Zero) by the dip-switch SW1 [5..8] (see TAB.3)
- 4) Set the maximum input value (Full scale) by the dip-switch SW2 [1..6] (see TAB.3)
- 5) Set the output type by the dip-switch SW2 [7..8] (see TAB.2)

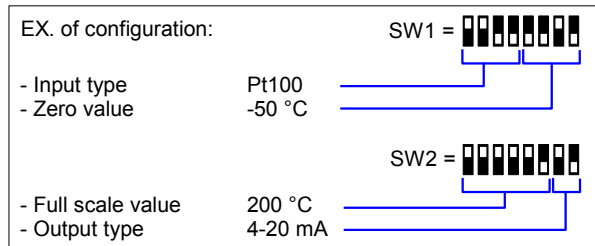

NOTE:

- It is also possible to set the dip-switches using the wizard of the configuration software following the procedure described in the section "Configuration by PC" until the step 6 and clicking on "Switch".

### DIP-SWITCH CONFIGURATION TABLES

TAB.1  
Input type settings

| SW1     | SW1     |
|---------|---------|
| 1 2 3 4 | 1 2 3 4 |
|         | EPROM * |
|         | R 2KΩ   |
|         | R 500Ω  |
|         | Pt100   |
|         | Ni100   |
|         | Pt1000  |
|         | Ni1000  |
|         | ---     |

TAB.2  
Output settings

| SW2 |         |
|-----|---------|
| 7 8 |         |
|     | 0-20 mA |
|     | 4-20 mA |
|     | 0-10 V  |
|     | 0-5 V   |

NOTES:

\* For all the input type selected by dip-switches, the compensation of wires is fixed at 3.

\* To configure the range for the input type selected (TAB.1) refer to the section of the TAB.3 on next page relative to it (ex: for Pt100 use the table TAB.3c).

\* If the dip-switches SW1 [1..4] are all set in the position 0 ("EPROM"), the device will follow the configuration programmed by PC (input type and range, output type and range and options).

\* If the dip-switches SW1 [5..8] are all set in the position 0 ("Default"), the device will follow the input scale programmed by PC for the input type selected by the dip-switches SW1 [1..4]

\* Eventual wrong dip-switches settings will be signalled by the blinking of the led "PWR".

TAB.3a – Settings for Resistance < 2KOhm

| Zero           |         | Full scale         |         |                    |      |                    |      |                    |      |
|----------------|---------|--------------------|---------|--------------------|------|--------------------|------|--------------------|------|
| SW1<br>5 6 7 8 | Ω       | SW2<br>1 2 3 4 5 6 | Ω       | SW2<br>1 2 3 4 5 6 | Ω    | SW2<br>1 2 3 4 5 6 | Ω    | SW2<br>1 2 3 4 5 6 | Ω    |
|                | Default |                    | Default |                    | 800  |                    | 1150 |                    | 1600 |
|                | 0       |                    | 500     |                    | 820  |                    | 1175 |                    | 1650 |
|                | 150     |                    | 520     |                    | 840  |                    | 1200 |                    | 1700 |
|                | 200     |                    | 540     |                    | 860  |                    | 1225 |                    | 1750 |
|                | 250     |                    | 560     |                    | 880  |                    | 1250 |                    | 1800 |
|                | 300     |                    | 580     |                    | 900  |                    | 1275 |                    | 1850 |
|                | 350     |                    | 600     |                    | 920  |                    | 1300 |                    | 1900 |
|                | 400     |                    | 620     |                    | 940  |                    | 1325 |                    | 1950 |
|                | 450     |                    | 640     |                    | 960  |                    | 1350 |                    | 2000 |
|                | 500     |                    | 660     |                    | 980  |                    | 1375 |                    | 2000 |
|                | 550     |                    | 680     |                    | 1000 |                    | 1400 |                    | 2000 |
|                | 600     |                    | 700     |                    | 1025 |                    | 1425 |                    | 2000 |
|                | 650     |                    | 720     |                    | 1050 |                    | 1450 |                    | 2000 |
|                | 700     |                    | 740     |                    | 1075 |                    | 1475 |                    | 2000 |
|                | 750     |                    | 760     |                    | 1100 |                    | 1500 |                    | 2000 |
|                | 800     |                    | 780     |                    | 1125 |                    | 1550 |                    | 2000 |

TAB.3b – Settings for Resistance < 500 ohm

| Zero           |         | Full scale         |         |                    |     |                    |     |                    |     |
|----------------|---------|--------------------|---------|--------------------|-----|--------------------|-----|--------------------|-----|
| SW1<br>5 6 7 8 | Ω       | SW2<br>1 2 3 4 5 6 | Ω       | SW2<br>1 2 3 4 5 6 | Ω   | SW2<br>1 2 3 4 5 6 | Ω   | SW2<br>1 2 3 4 5 6 | Ω   |
|                | Default |                    | Default |                    | 125 |                    | 210 |                    | 370 |
|                | 0       |                    | 50      |                    | 130 |                    | 220 |                    | 380 |
|                | 10      |                    | 55      |                    | 135 |                    | 230 |                    | 390 |
|                | 20      |                    | 60      |                    | 140 |                    | 240 |                    | 400 |
|                | 30      |                    | 65      |                    | 145 |                    | 250 |                    | 410 |
|                | 40      |                    | 70      |                    | 150 |                    | 260 |                    | 420 |
|                | 50      |                    | 75      |                    | 155 |                    | 270 |                    | 430 |
|                | 75      |                    | 80      |                    | 160 |                    | 280 |                    | 440 |
|                | 100     |                    | 85      |                    | 165 |                    | 290 |                    | 450 |
|                | 125     |                    | 90      |                    | 170 |                    | 300 |                    | 460 |
|                | 150     |                    | 95      |                    | 175 |                    | 310 |                    | 470 |
|                | 175     |                    | 100     |                    | 180 |                    | 320 |                    | 480 |
|                | 200     |                    | 105     |                    | 185 |                    | 330 |                    | 490 |
|                | 225     |                    | 110     |                    | 190 |                    | 340 |                    | 500 |
|                | 250     |                    | 115     |                    | 195 |                    | 350 |                    | 500 |
|                | 300     |                    | 120     |                    | 200 |                    | 360 |                    | 500 |

TAB.3c – Settings for Pt100, Pt1K, Ni100, Ni1K

| Zero           |         | Full scale         |         |                    |     |                    |     |                    |     |
|----------------|---------|--------------------|---------|--------------------|-----|--------------------|-----|--------------------|-----|
| SW1<br>5 6 7 8 | °C      | SW2<br>1 2 3 4 5 6 | °C      | SW2<br>1 2 3 4 5 6 | °C  | SW2<br>1 2 3 4 5 6 | °C  | SW2<br>1 2 3 4 5 6 | °C  |
|                | Default |                    | Default |                    | 75  |                    | 210 |                    | 370 |
|                | -200    |                    | 0       |                    | 80  |                    | 220 |                    | 380 |
|                | -150    |                    | 5       |                    | 85  |                    | 230 |                    | 390 |
|                | -100    |                    | 10      |                    | 90  |                    | 240 |                    | 400 |
|                | -50     |                    | 15      |                    | 95  |                    | 250 |                    | 425 |
|                | -40     |                    | 20      |                    | 100 |                    | 260 |                    | 450 |
|                | -30     |                    | 25      |                    | 110 |                    | 270 |                    | 475 |
|                | -20     |                    | 30      |                    | 120 |                    | 280 |                    | 500 |
|                | -10     |                    | 35      |                    | 130 |                    | 290 |                    | 525 |
|                | 0       |                    | 40      |                    | 140 |                    | 300 |                    | 550 |
|                | 5       |                    | 45      |                    | 150 |                    | 310 |                    | 600 |
|                | 10      |                    | 50      |                    | 160 |                    | 320 |                    | 650 |
|                | 20      |                    | 55      |                    | 170 |                    | 330 |                    | 700 |
|                | 30      |                    | 60      |                    | 180 |                    | 340 |                    | 750 |
|                | 50      |                    | 65      |                    | 190 |                    | 350 |                    | 800 |
|                | 100     |                    | 70      |                    | 200 |                    | 360 |                    | 850 |

## INSTALLATION INSTRUCTIONS

The device is suitable for fitting to DIN rails in the vertical position.  
For optimum operation and long life follow these instructions:

**When the devices are installed side by side it may be necessary to separate them by at least 5 mm in the following cases:**

- If panel temperature exceeds 45°C.
- Use of high power supply value ( $> 27$  Vdc ).
- Use of output current.

Make sure that sufficient air flow is provided for the device avoiding to place raceways or other objects which could obstruct the ventilation slits. Moreover it is suggested to avoid that devices are mounted above appliances generating heat; their ideal place should be in the lower part of the panel.

Install the device in a place without vibrations.

Moreover it is suggested to avoid routing conductors near power signal cables (motors, induction ovens, inverters etc...) and to use shielded cable for connecting signals.

## ISOLATION STRUCTURE



## CONNECTIONS

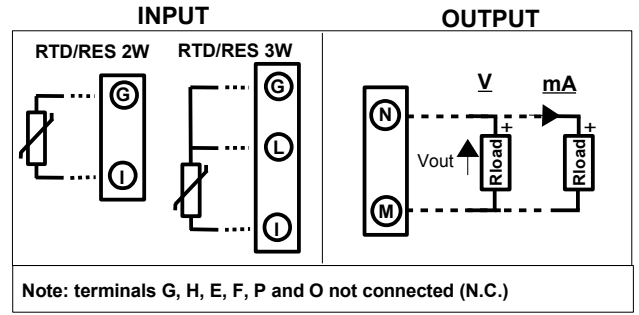

## POWER SUPPLY(\*)

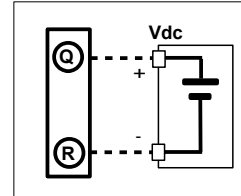

(\*) Note: for UL installation the device must be powered using a power supply unit classified NEC class 2 or SELV

## LIGHT SIGNALLING

| LED | COLOUR | STATE    | DESCRIPTION                |
|-----|--------|----------|----------------------------|
| PWR | GREEN  | ON       | Device powered             |
|     |        | OFF      | Device not powered         |
|     |        | BLINKING | Wrong dip-switches setting |

## DIMENSIONS (mm)

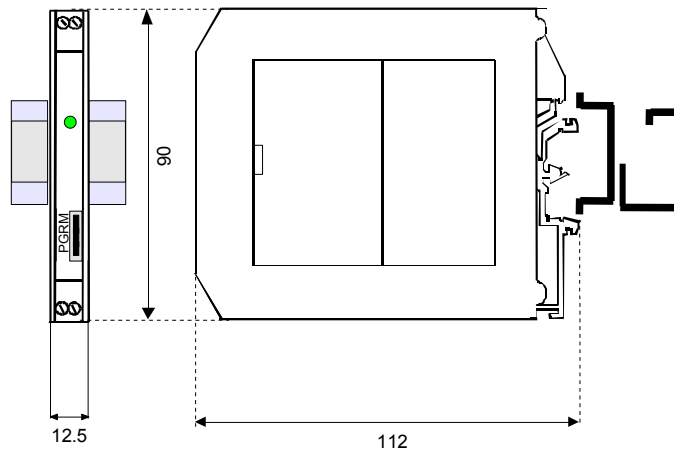

## HOW TO ORDER

The device is provided as requested on the Customer's order.  
Refer to the section "Programming" to determine the input and output ranges.  
In case of the configuration is not specified, the parameters must be set by the user.

### ORDER CODE EXAMPLE:

**DAT 4531B / Pt100 / 0 ÷ 200 °C / 4 ÷ 20 mA / 3 wires**

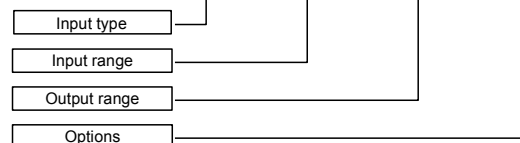

The symbol reported on the product indicates that the product itself must not be considered as a domestic waste. It must be brought to the authorized recycle plant for the recycling of electrical and electronic waste. For more information contact the proper office in the user's city, the service for the waste treatment or the supplier from which the product has been purchased.