

DAT9000-IO-USB-2.0

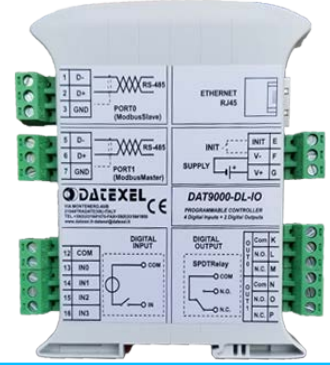

FEATURES

- N.1 serial interface RS-485 Modbus RTU Master
- N.1 serial interface RS-485/uUSB Modbus RTU Slave
- N.1 slot for USB memory stick
- Interface Ethernet 10/100Base-T, Modbus TCP Client/Server
- N.4 Digital Inputs with 32 bit pulse counters + N.2 SPDT relays
- Master both on RS-485 (Modbus RTU) and on Ethernet (Modbus TCP)
- Programming software with "flow chart" structure
- Connection by removable screw-terminals
- Programmable without external sources via uUSB and CVPROG cable
- LED signalling for Link/Act Ethernet, serial RX-TX, power supply
- LED signalling for digital inputs and outputs status
- Galvanic Isolation on all the ways
- EMC compliance – CE mark
- Suitable for DIN rail mounting in compliance with EN-50022 standard

GENERAL DESCRIPTION

The device DAT9000-IO-USB is an Intelligent unit able to control a network of slave Modbus RTU devices connected on serial line RS-485 Master or Modbus TCP through the Ethernet interface executing the reading and writing of the field values and performing the logical and mathematical functions necessary for the system working, managing up to 10 task of recording memorized on files saved on the USB device. The device is equipped with 4 digital inputs channels and 2 relay outputs. A 32-bit pulse counter is available for each digital input.

By means of the Ethernet interface or the RS-485 "SLAVE" or uUSB ports it is possible to read and write, in real time, the internal registers value.

By Ethernet it is possible to get access to the files saved on the USB device when the Data-Logger function is active.

The supplied CVPROG cable allows you to configure / program the device without using an external power supply.

Moreover, by means of the Ethernet interface, or by the RS-485 "SLAVE" or uUSB ports it is possible to:

- Programming of the Control Logic
- Monitor, request of data, programming in real time the Intelligent Unit
- Direct programming and request of data from the Slave devices connected to the RS-485 Master.

The device DAT9000-IO-USB is configurable by the software DEV9K 2.0 and successive versions developed by DATEXEL and running under Windows.

The device DAT9000-IO-USB realizes a full electrical isolation between the lines, introducing a valid protection against the effects of all ground loops eventually existing in industrial applications.

LED signalling of Ethernet activity and data Rx-Tx flow on the serial line allows a direct monitoring of the system functionality.

The connection is made by removable screw-terminals (supply and RS-485) and RJ45 plug (Ethernet).

The device is housed in a rough self-extinguishing plastic enclosure which, thanks to its thin profile of 22.5 mm only, allows a high density mounting on EN-50022 standard DIN rail.

SUPPORTED FUNCTION

The DAT9000 series devices support the standard Modbus write and read functions (see Device User Guide), mathematical operations, logic operations and calculation functions (Scaling, Average, root extraction, ...)

For the complete list of functions and their operation, refer to the Programming software User Guide.

TECHNICAL SPECIFICATIONS (Typical @ 25 °C and in the nominal conditions)

In compliance with Ethernet IEEE 802.3 EIA RS485		Digital Inputs		Power supply	
		Channels	4	Current consumption	18 ÷ 30 Vdc 45 mA typ. @ 24Vdc (standby) 100 mA max
Network interface	Ethernet 10/100Base-T	Input voltage (bipolar)		Isolations	
Protocol	Modbus TCP	OFF state	0 ÷ 3 V	Power supply / Ethernet	1500 Vac, 50 Hz, 1 min.
IP Table size	max 8 devices (IP)	ON state	10 ÷ 30 V	Power supply / RS485	1500 Vac, 50 Hz, 1 min.
Socket Modbus TCP	16 (port 502)	Impedance	4,7 KΩ	Ethernet / RS485	1500 Vac, 50 Hz, 1 min.
Socket HTTP	3 (port 80)	Pulse counters	4 at 32 bit	Inputs / RS485	1500 Vac, 50 Hz, 1 min.
				Inputs / Power supply	1500 Vac, 50 Hz, 1 min.
RS485 Interface		Max signal frequency		Connections	
Baud-rate	up to 115.2 Kbps			Ethernet	RJ-45 (on terminals side)
Max. distance (1)	1,2 Km @ 115.2 Kbps			uUSB	uUSB micro-B (up front)
Protocol	Modbus RTU			RS-485 / Supply /In / Out	Removable screw terminals
Number of modules in multipoint	up to 32	Digital Outputs		Environmental Conditions	
Compatible USB devices and datalogger		Channels	2	Operative temperature	-20 ÷ +60 °C
Type	Pen drive	Type	SPDT Relays	Storage temperature	-40 ÷ +85 °C
Memory size	Up to 32 GB	Switching Power (max.)		Relative humidity (not cond.)	0 ÷ 90 %
Format	FAT16 or FAT32	2 A @ 250 Vac (resistive load) per contact		Maximum Altitude	2000 m
N° Logging task	up to 10	2 A @ 30 Vdc (resistive load) per contact		Installation	Indoor
Min. schedule rate	10 seconds	Max. voltage 250Vac (50 / 60 Hz) , 30Vdc		Category of installation	II
		Dielectric strength between contacts		Pollution Degree	2
		1000 Vac, 50 Hz, 1 min.		Mechanical Specifications	
		Dielectric strength between coil and contacts		Material	Self-extinguish plastic
		4000 Vac, 50 Hz, 1 min.		IP Code	IP20
				Wiring	wires with diameter 0.8÷2.1 mm ² /AWG 14-18
				Tightening Torque	0.8 N m
				Mounting	in compliance with DIN rail standard EN-50022
				Dimensions in mm.(WxHxT)	100 x 120 x 22.5
				Weight	about 160 gr.
				EMC (for industrial environments)	
				Immunity	EN 61000-6-2
				Emission	EN 61000-6-4

(1) – The maximum distance depends of: number of devices connected, type of cabling, noises, etc...

INSTALLATION INSTRUCTIONS

The Intelligent Unit DAT9000-IO-USB is suitable for fitting to DIN rails in the vertical position.

For optimum operation and long life follow these instructions:

When the devices are installed side by side it may be necessary to separate them by at least 5 mm in the following case:

- If panel temperature exceeds 45°C and high power supply value(> 27Vdc).
Make sure that sufficient air flow is provided for the device avoiding to place raceways or other objects which could obstruct the ventilation slits. Moreover it is suggested to avoid that devices are mounted above appliances generating heat; their ideal place should be in the lower part of the panel.
Install the device in a place without vibrations.

Moreover it is suggested to avoid routing conductors near power signal cables (motors, induction ovens, inverters, etc...) and to use shielded cable for connecting signals.

LIGHT SIGNALLING

LED	COLOR	STATE	DESCRIPTION
PWR	GREEN	ON	Device powered
		OFF	Device not powered
		BLINK	Watchdog Alarm
STS	YELLOW	BLINK	DEBUG modality
		OFF	RELEASE modality
RX <i>n</i>	RED	BLINK	PORT <i>n</i> – Data received (the blink frequency depends on Baud-rate)
		OFF	No reception in progress.
TX <i>n</i>	RED	BLINK	PORT <i>n</i> – Data transmitted (the blink frequency depends on Baud-rate)
		OFF	No reception in progress.
I <i>n</i>	RED	ON	State 1 Digital Inputs.
		OFF	State 0 Digital Inputs.
O <i>n</i>	RED	ON	State 1 Digital Outputs.
		OFF	State 0 Digital Outputs.

CONNECTIONS

SERIAL PORT CONNECTIONS

RS-485 Slave (Port 0)

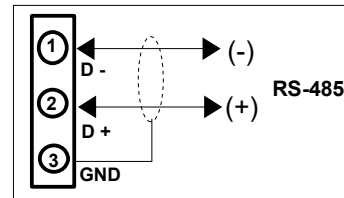

RS-485 Master (Port 1)

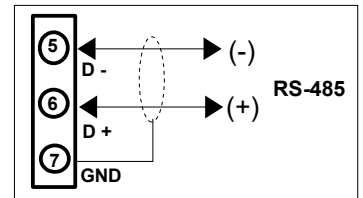

POWER SUPPLY CONNECTIONS

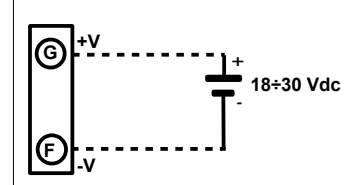

INIT CONNECTIONS

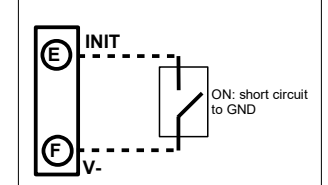

DIGITAL INPUTS

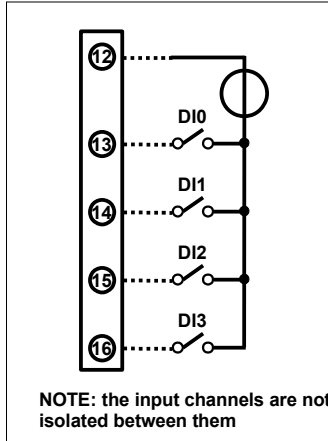

RELAY OUTPUTS

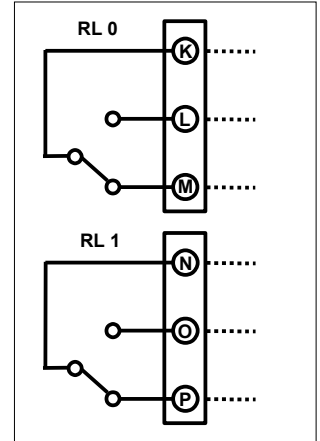

ACCESS TO THE INTEGRATED WEB SERVER "

To access the integrated web server, open a browser on your PC and type the IP address of the device in the address bar of the browser.

- **Factory IP Address:** 192.168.1.100

WARNING: make sure that the PC is in the same subnet as the device in use (see user guide of the device).

The factory / default login credentials that are requested on the "Login" page are:

- **Username:** Fact_user

- **Password:** Fact_pwd

Once you have logged in for the first time, you can change the credentials in the "Username and Password" section.

INSULATIONS

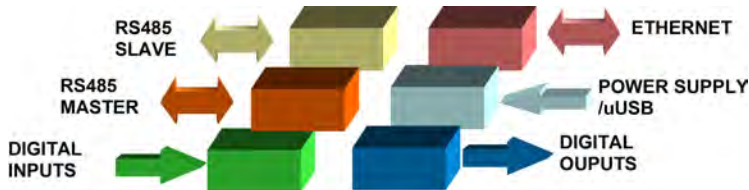

MECHANICAL DIMENSIONS (mm)

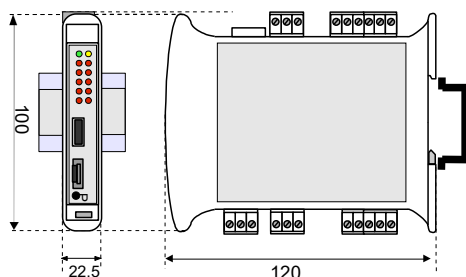

The symbol reported on the product indicates that the product itself must not be considered as a domestic waste. It must be brought to the authorized recycle plant for the recycling of electrical and electronic waste. For more information contact the proper office in the user's city , the service for the waste treatment or the supplier from which the product has been purchased.

PUSH-BUTTON "P" FUNCTIONALITY

This button, located on the front of the device allow to load the following factory defaults in the following two modes:

A) With the device on, press the button until the green LED (PW) goes off; immediately after release it to load the factory default parameters (modbus parameters, default IP, login credentials to the web server).

B) Turn on the device by keeping the button pressed and keep the pressure until the green LED (PW) goes off; immediately after release it to load the factory firmware.

While the default parameters or the factory firmware are loaded, the yellow STS LED remains permanently switched on. At the end of the loading it switches off.

ATTENTION: do not switch off the device during the loading phase!

"CVPROG" INTERFACE CABLE

The CVPROG cable is an interface consisting of the physical cable, a uUSB port that must be connected to the DATEXEL device in use, a USB port that must be connected to the user PC and a chip to recognize the USB port as VCP (Virtual Com Port).

Due to this the CVPROG interface cable is not a simple uUSB-USB cable.

Through the CVPROG cable it is possible to communicate and program the DATEXEL devices without external power.

This allows a simple use of the device.

WARNING: the uUSB port and the RS485 slave port (Port 0) cannot be used simultaneously and the communication parameters are common to both ports.

When connecting the CVPROG cable to the PC, it will be necessary to install the drivers supplied with the CDROM supplied with the device or downloaded from the website www.datexel.it

Verify of the generated COM port

When the CVPROG cable is inserted into the PC, a virtual COM port is automatically generated and it can be displayed in the "Device Management" window → Ports (COM and LPT) of the operating system in use.

HOW TO ORDER

" DAT9000-IO-USB-2.0 "

■ = Requested
□ = Optional